

MANURHIN K'MX 916CLEVER

Innovative technology

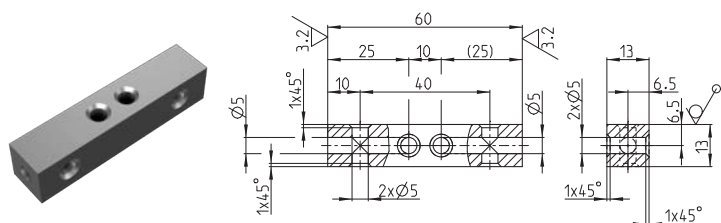
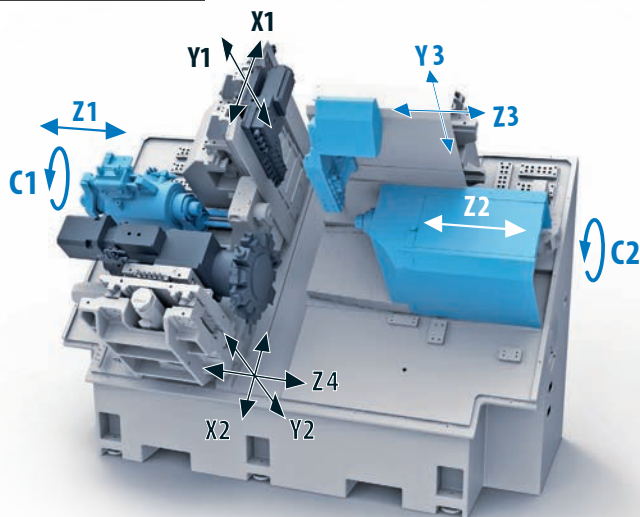

MANURHIN K'MX 916CLEVER

Hliník EN AW 6061	Mosaz CuZn39Pb3	Automatová ocel 1.0737	Nerezová ocel 1.4301
24 s	25 s	29 s	47 s

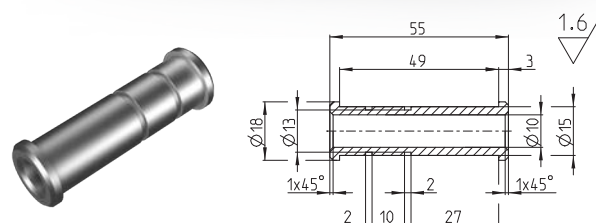

MANURHIN K'MX 916CLEVER

Hliník EN AW 6061	Mosaz CuZn39Pb3	Automatová ocel 1.0737	Nerezová ocel 1.4301
19 s	22 s	27 s	48 s

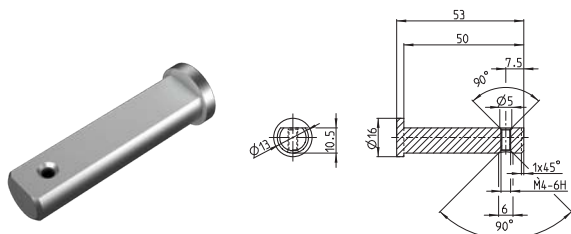

MANURHIN K'MX 916CLEVER

Hliník EN AW 6061	Mosaz CuZn39Pb3	Automatová ocel 1.0737	Nerezová ocel 1.4301
25 s	30 s	41 s	59 s

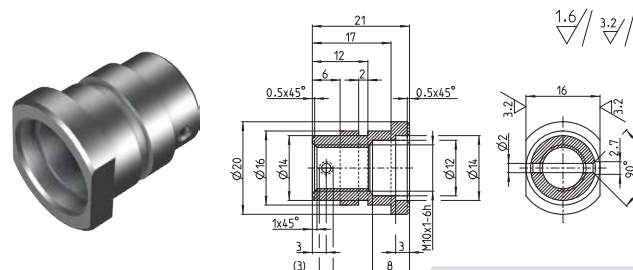

MANURHIN K'MX 916CLEVER

Hliník EN AW 6061	Mosaz CuZn39Pb3	Automatová ocel 1.0737	Nerezová ocel 1.4301
29 s	30 s	35 s	56 s

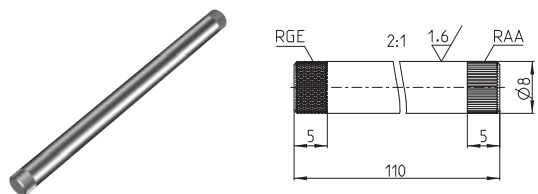

MANURHIN K'MX 916CLEVER

Hliník EN AW 6061	Mosaz CuZn39Pb3	Automatová ocel 1.0737	Nerezová ocel 1.4301
25 s	27 s	32 s	43 s

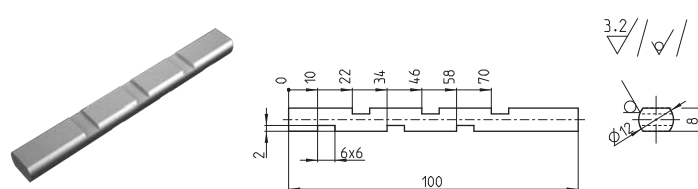

MANURHIN K'MX 916CLEVER

Hliník EN AW 6061	Mosaz CuZn39Pb3	Automatová ocel 1.0737	Nerezová ocel 1.4301
38 s	39 s	42 s	81 s

Čas obrábění dílce je kalkulován při použití standardních nástrojů, bez speciálních technologií, vysokotlakého chlazení skrz nástroje a s ohledem na optimální životnost používaných nástrojů.