

Příslušenství pro CNC dlouhotočný automat

ACCESSORIES FOR CNC SLIDING HEADSTOCK MACHINE
ZUBEHÖR FÜR CNC-LANGDREHAUTOMAT
ACCESSORI PER MACCHINA AUTOMATICA CNC A FANTINA MOBILE
ACCESSOIRES POUR TOURS A POUPEE MOBILE
ПРИНАДЛЕЖНОСТИ ДЛЯ АВТОМАТА ПРОДОЛЬНОГО ТОЧЕНИЯ С ЧПУ

K'MX 816

K'MX 916

22.2.2019



Obsah

Průvodce katalogem.....	3
Průvodce katalogem.....	4
Držák nožů	5
Držák nožů s chlazením	6
Podložka držáku nože.....	7
Držák pro nůž s vnitřním chlazením	8
Držák osových nástrojů	9
Držák osových nástrojů	10
Držák osových nástrojů	11
Držák osových nástrojů	12
Držák kleštinový	13
Držák kleštinový	14
Pásový dopravník	15
Lineární odměřování	16
Automatické otevírání dveří.....	17
Rotační jednotka B-osa.....	18
Pneumatické vodící pouzdro	19
Příslušenství pro obrábění bez vodícího pouzdra	20
Dopravník třísek listový.....	21
Vana pod stroj	22
Odvod dlouhých dílců.....	23
Vložka pro kleštinu	24
Příslušenství rotační jednotky	25
Příslušenství rotační jednotky	26
Osový držák	27
Převodovka pro jednotky WTO	28
Vrtací a frézovací jednotka WTO.....	29
Vrtací a frézovací jednotka WTO.....	30
Vrtací a frézovací jednotka WTO.....	31

Vrtací a frézovací jednotka WTO.....	32
Frézovací jednotka WTO	33
Jednotka pro odvalovací frézování WTO.....	34
Úhlově nastavitelná vrtací a frézovací jednotka WTO	35
Jednotka pro okružní frézování závitů WTO	36
Jednotka pro okružní frézování závitů WTO	37
Rotační jednotka pro revolverovou hlavu (KMX 916).....	38
Rotační jednotka pro revolverovou hlavu (KMX 916).....	39
VDI držák nožů pravý (KMX 916).....	40
VDI držák nožů levý (KMX 916)	41
Oplach u vodícího pouzdra.....	42
Držák osových nástrojů	43
Vysokotlaké chlazení – agregát	44
Vysokotlaké chlazení – přívod chladiva.....	45
Redukce vřetene pro různé průměry materiálu.....	46
Připojení podavače tyčí	47
Výplach protivřetena.....	48
Upínání při vysokých otáčkách	49
Odsavač par	50

Průvodce katalogem

CATALOGUE GUIDE
KATALOGBEGLEITER
GUIDA AL CATALOGO
EXPLICATION DU CATALOGUE
ОРИЕНТИРОВКА В КАТАЛОГЕ

K'MX 816

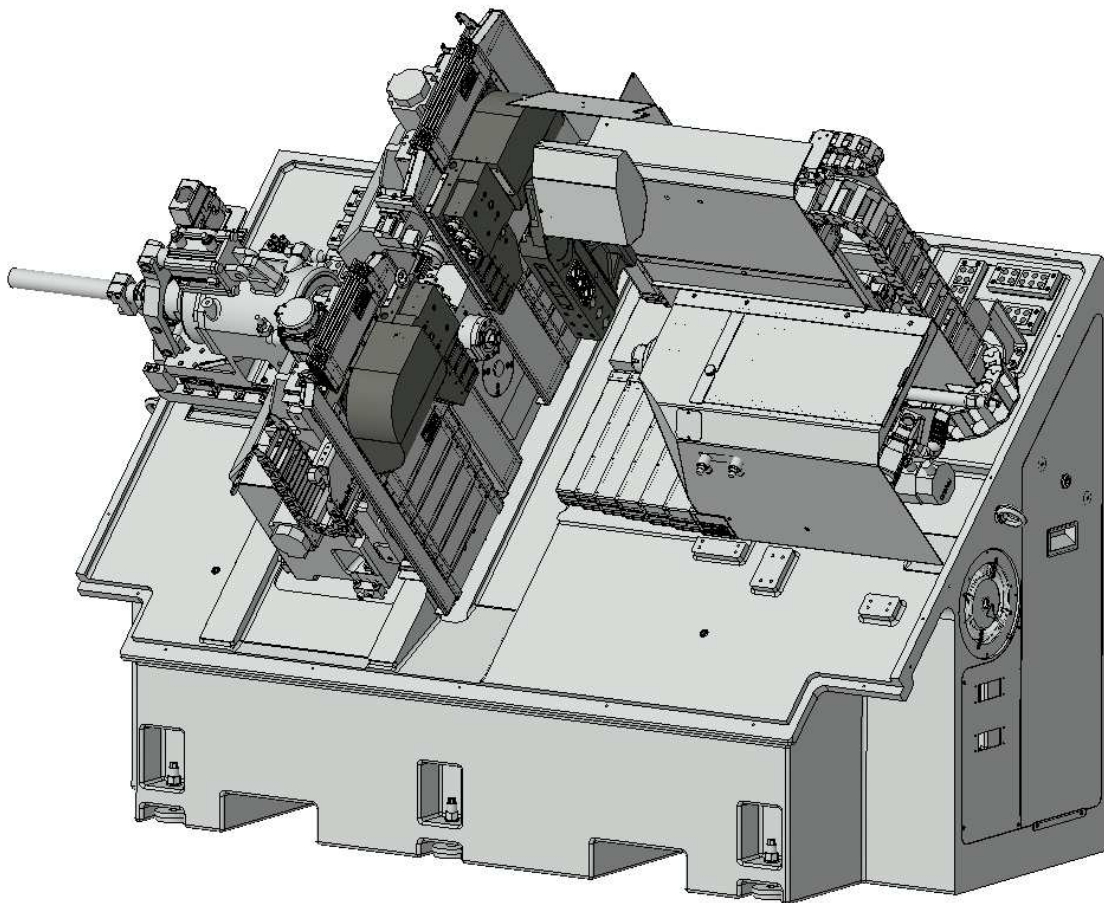

Průvodce katalogem

CATALOGUE GUIDE
KATALOGBEGLEITER
GUIDA AL CATALOGO
EXPLICATION DU CATALOGUE
ОРИЕНТИРОВКА В КАТАЛОГЕ

K'MX 916

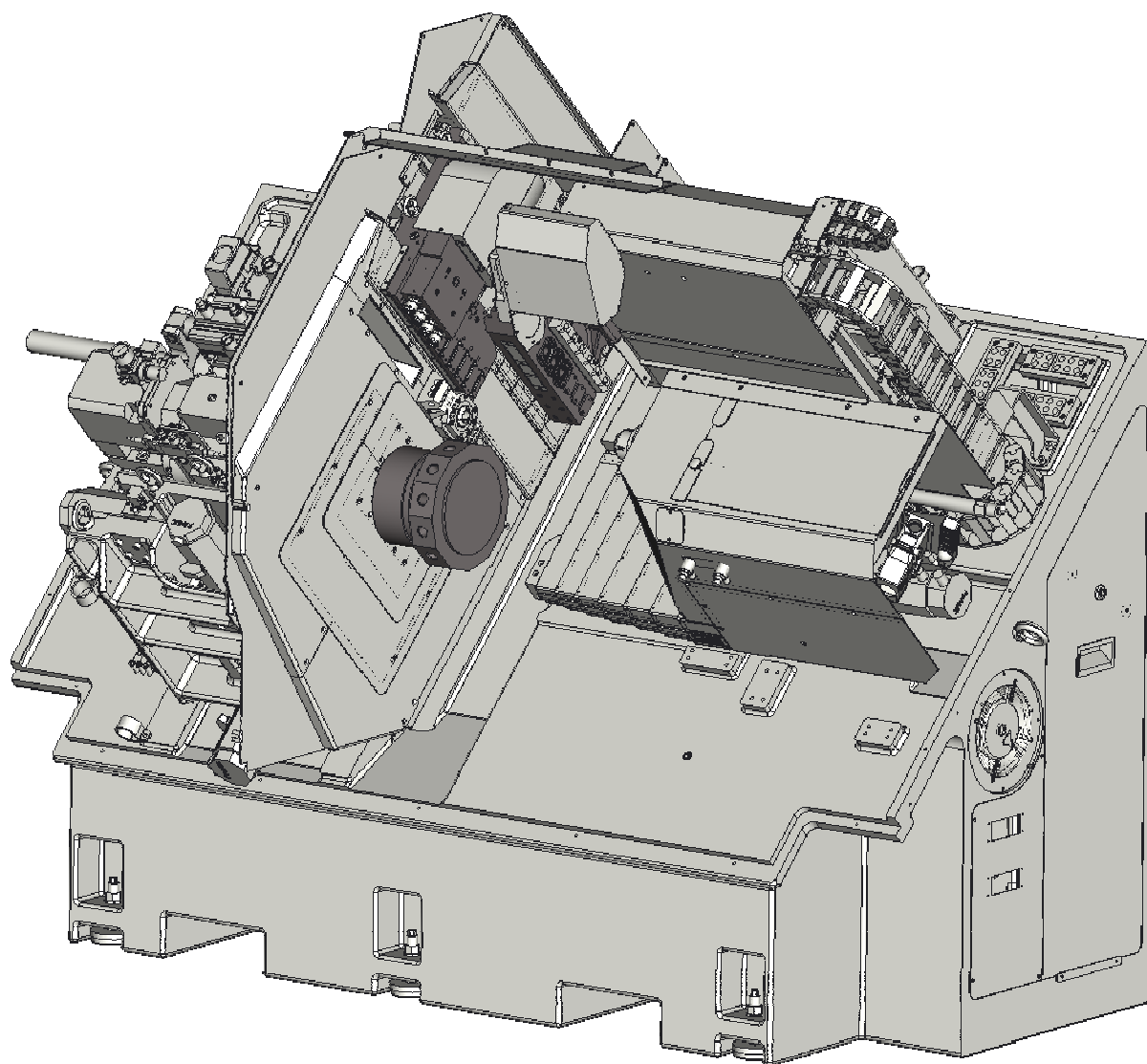

Držák nožů

TOOL HOLDER

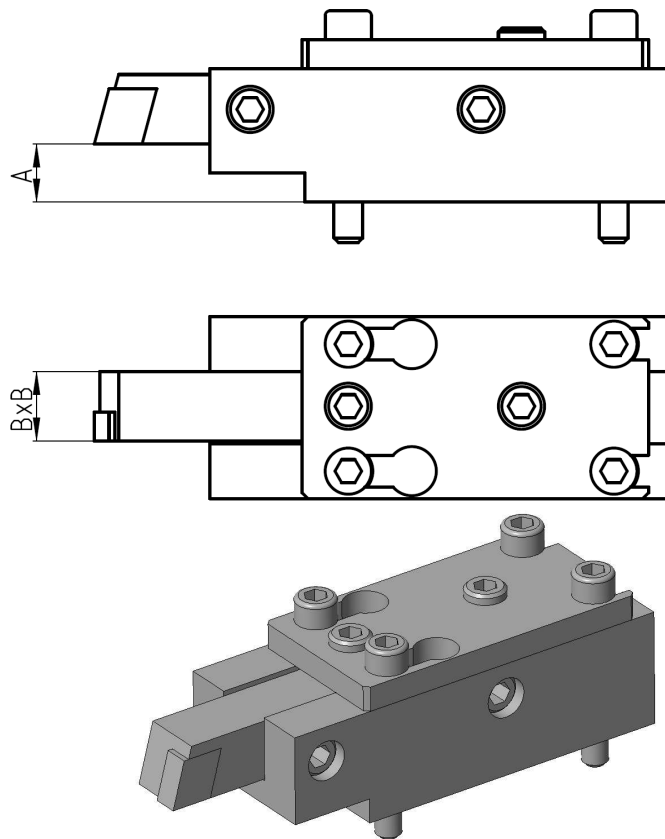

	A	B
R950LV1P1.01	10 mm	12 mm
R950LV1P2	9 mm	8 mm
R950LV1P3	7.5 mm	12 mm

Držák nožů s chlazením

TOOL HOLDER WITH COOLING

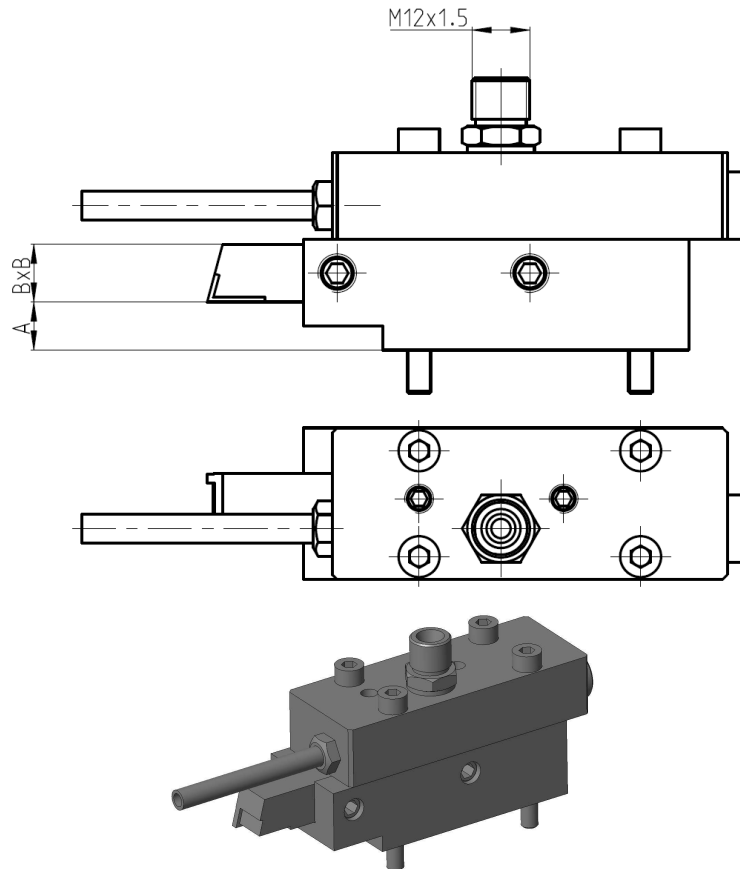

	A	B
R950LV20P2	10 mm	12 mm

Podložka držáku nože

TOOLHOLDER BASE

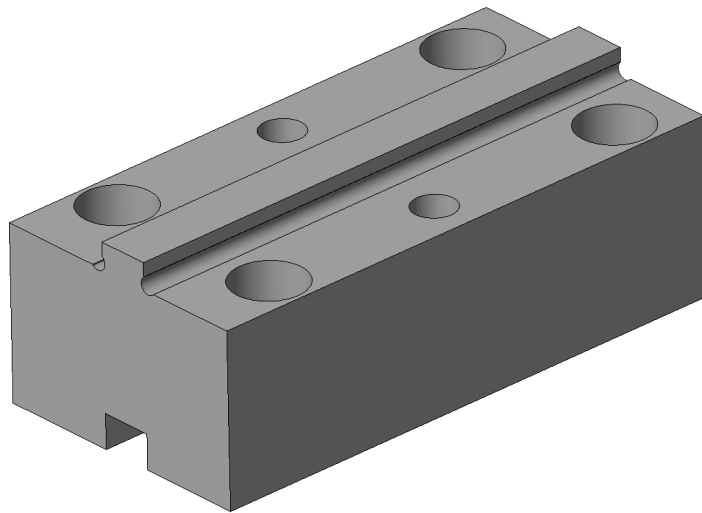
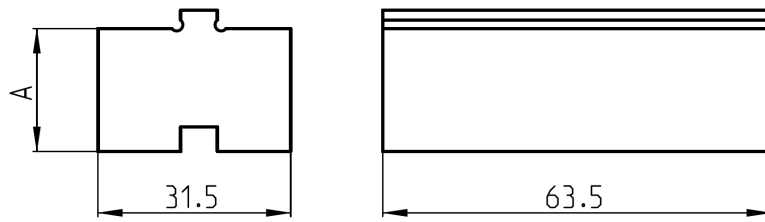

	A
R950LV31P3	20 mm
R950LV31P4	15 mm

Držák pro nůž s vnitřním chlazením

HOLDER FOR TOOLS WITH INTERNAL COOLING

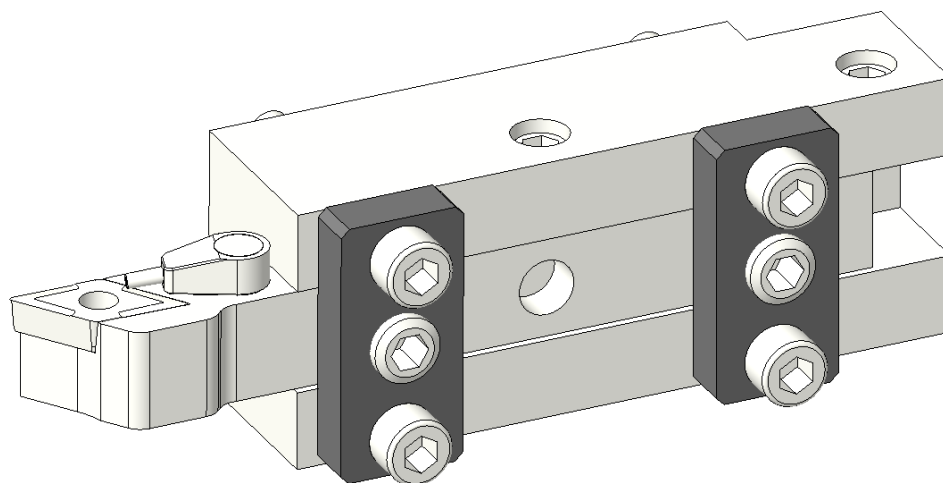

R951L1407E1

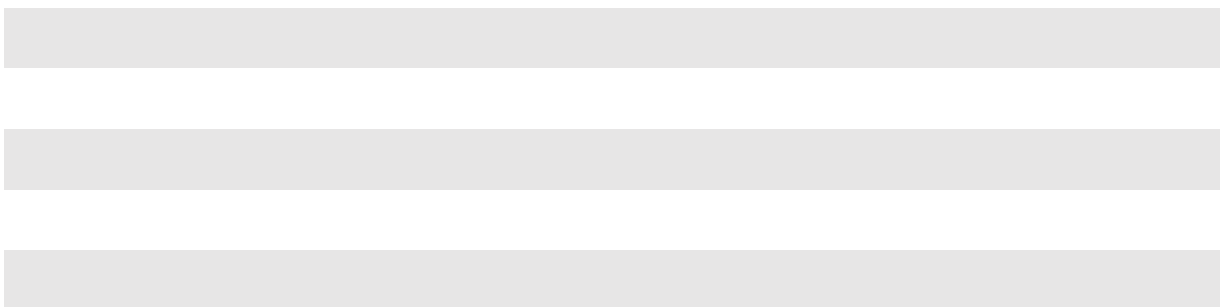

Držák osových nástrojů

AXIAL TOOL HOLDER

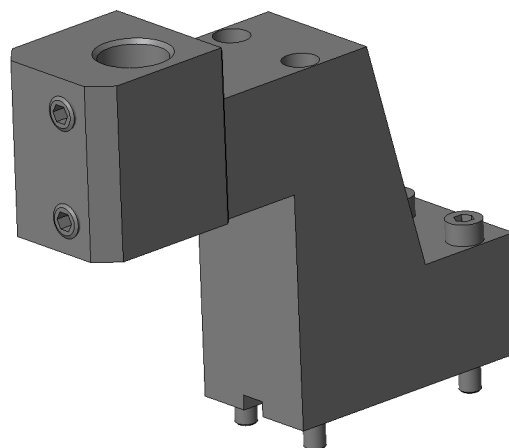
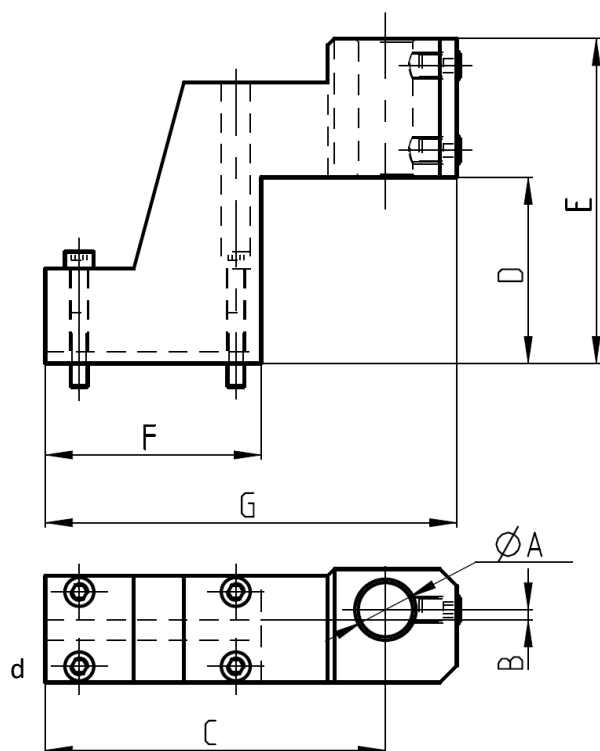

	A	B	C	D	E	F	G
950LV14P1	16 mm	3 mm	100 mm	78 mm	118 mm	63,5 mm	118 mm
950LV14P2	16 mm	3 mm	100 mm	66,5 mm	107 mm	63,5 mm	118 mm
950LV14P3	16 mm	3 mm	100 mm	30 mm	70 mm	63,5 mm	118 mm
950LV14P4	16 mm	3 mm	100 mm	38,5 mm	79 mm	63,5 mm	118 mm
950LV14P5	16 mm	3 mm	100 mm	55 mm	96 mm	63,5 mm	121 mm

Držák osových nástrojů

AXIAL TOOL HOLDER

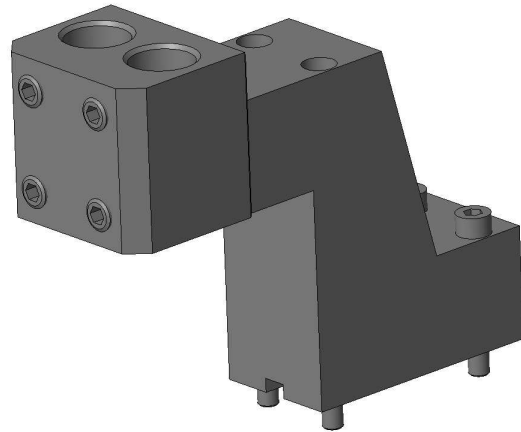
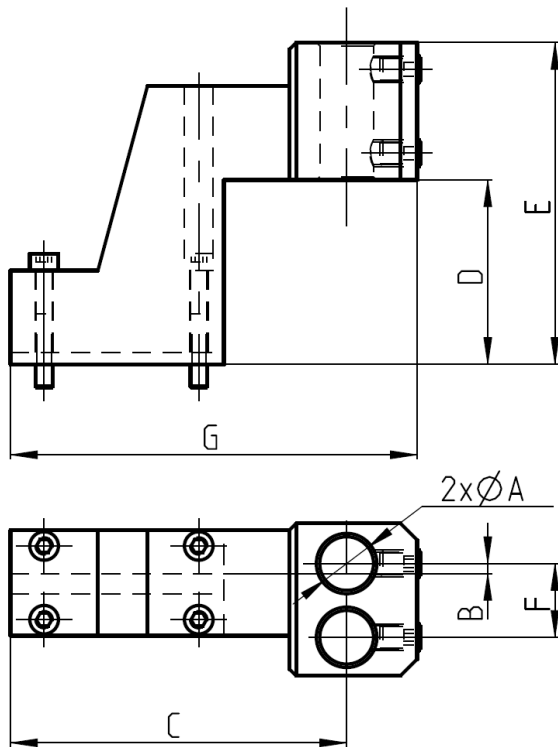

	A	B	C	D	E	F	G
950LV14P6	16 mm	3 mm	100 mm	55 mm	96 mm	22 mm	121 mm

Držák osových nástrojů

AXIAL TOOL HOLDER

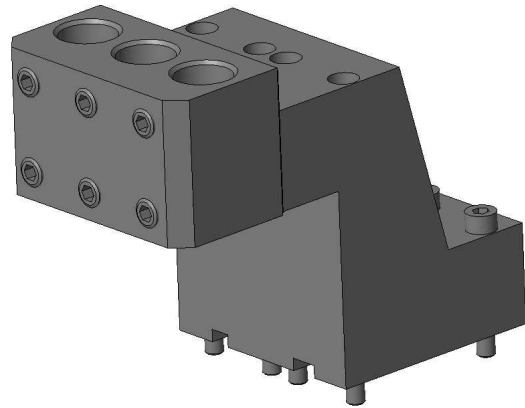
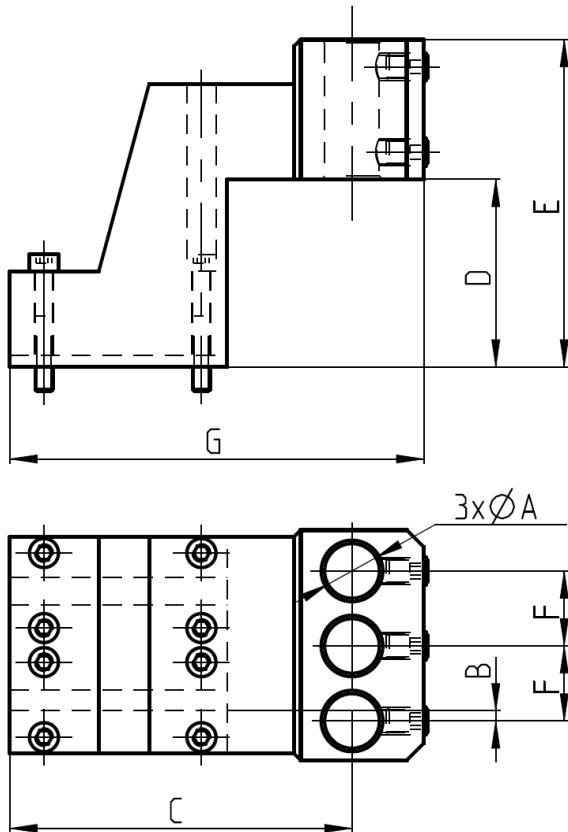

	A	B	C	D	E	F	G
950LV14P7	16 mm	3 mm	100 mm	55 mm	96 mm	22 mm	121 mm

Držák osových nástrojů

AXIAL TOOL HOLDER

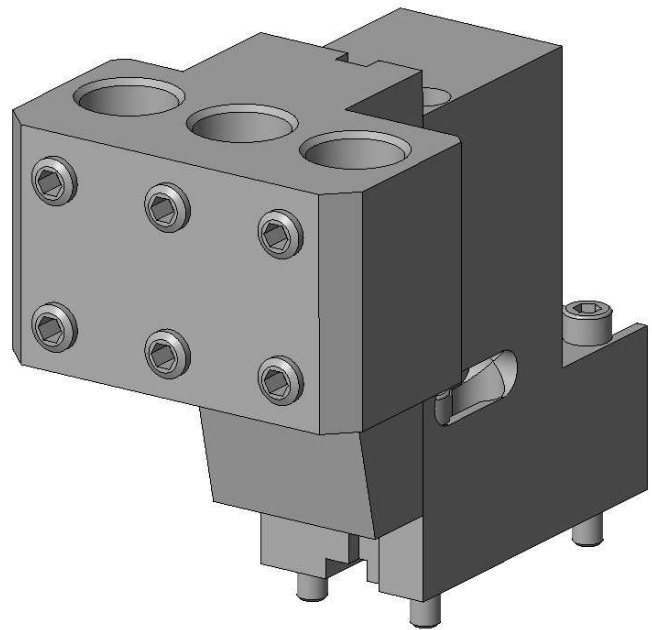
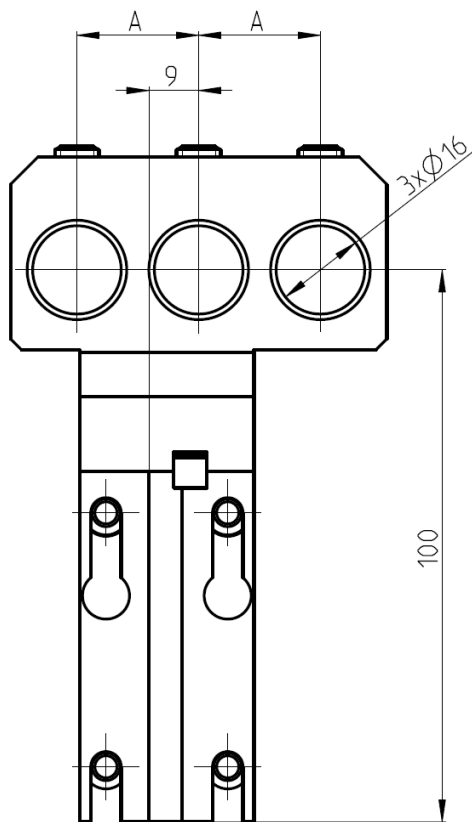

A

950LV3P1 22 mm

950LV3P2 25 mm

Držák kleštinový

COLLET HOLDER
 BOHRERHALTER
 PORTAPINZA
 PORTE PINCE
 ДЕРЖАТЕЛЬ ЦАНГОВЫЙ

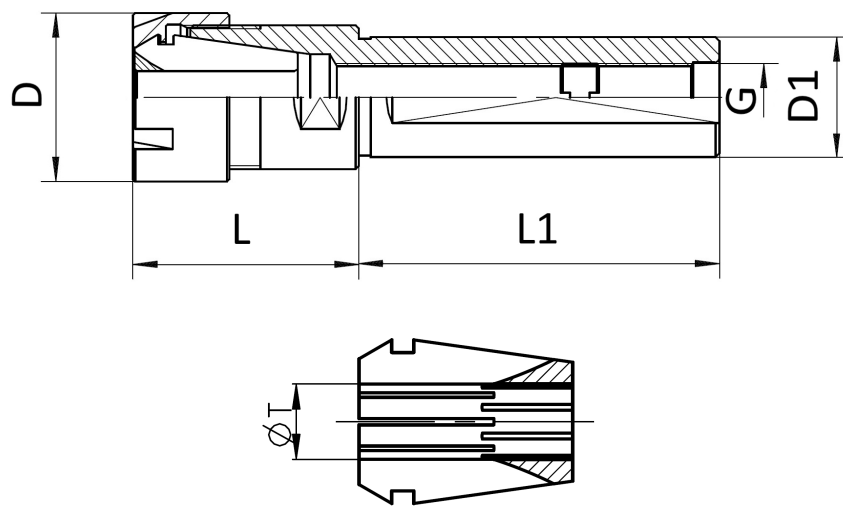

		MAX. T	D	D1	L	L1	G
950LV16P42	ER 11	7 mm	16 mm	16 mm	20 mm	38 mm	M8x1

Držák kleštinový

COLLET HOLDER
BOHRERHALTER
PORTAPINZA
PORTE PINCE
ДЕРЖАТЕЛЬ ЦАНГОВЫЙ

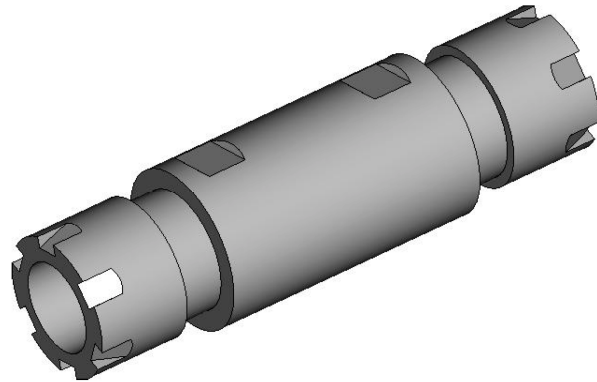
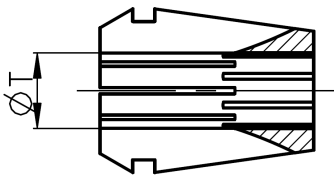
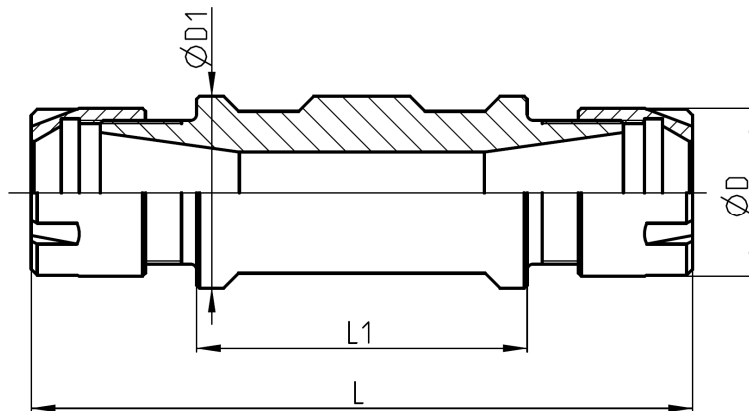

		MAX. T	D	D1	L	L1
950LV16P39	ER 11	7 mm	16 mm	16 mm	90 mm	50 mm
950LV16P47	ER 11	7 mm	16 mm	16 mm	79 mm	40 mm

Pásový dopravník
BELT CONVEYOR

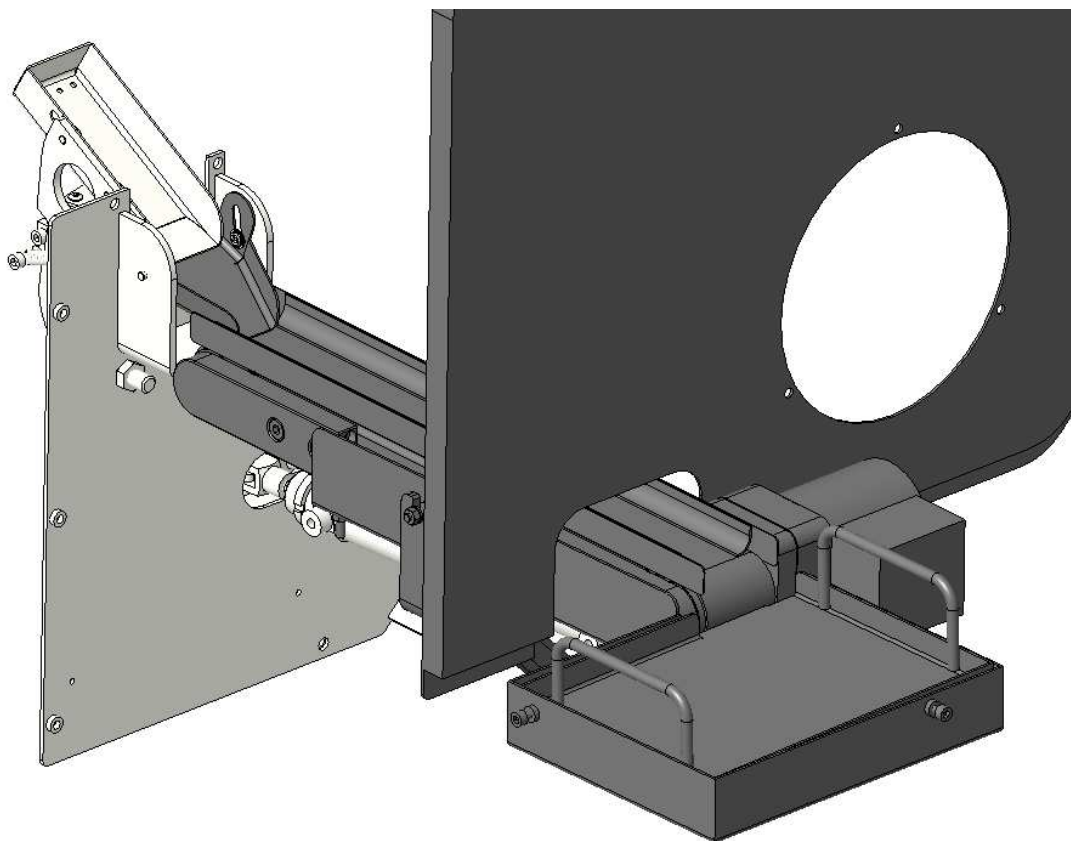

R952LV31P2

Lineární odměřování

LINEAR SCALE



Zdroj [<http://www.heidenhain.com>]

R952LV41P5 FANUC

R952LV41P6 MITSUBISHI

Automatické otevíraní dveří

AUTOMATIC DOOR

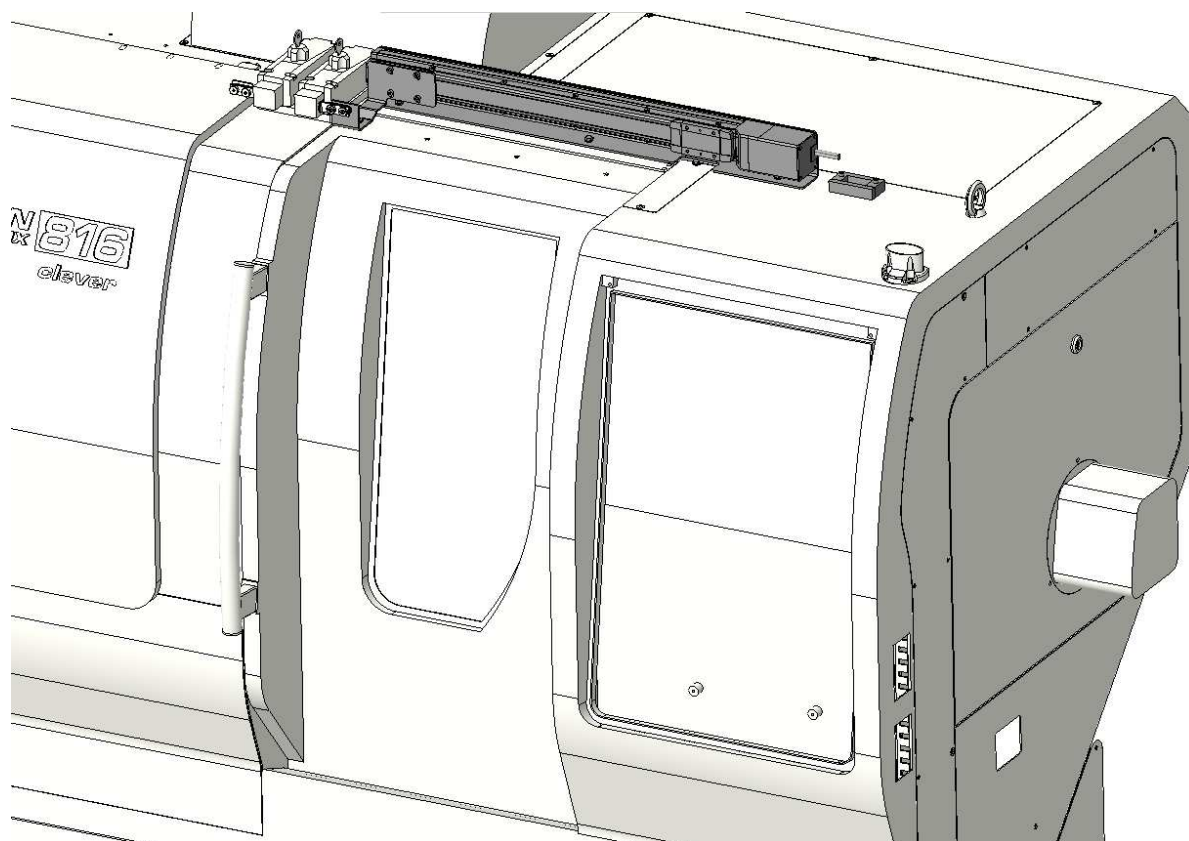

R952LV57P1

Rotační jednotka B-osa
DRILL AND MILLING UNIT B-AXIS

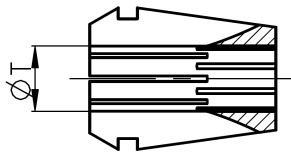
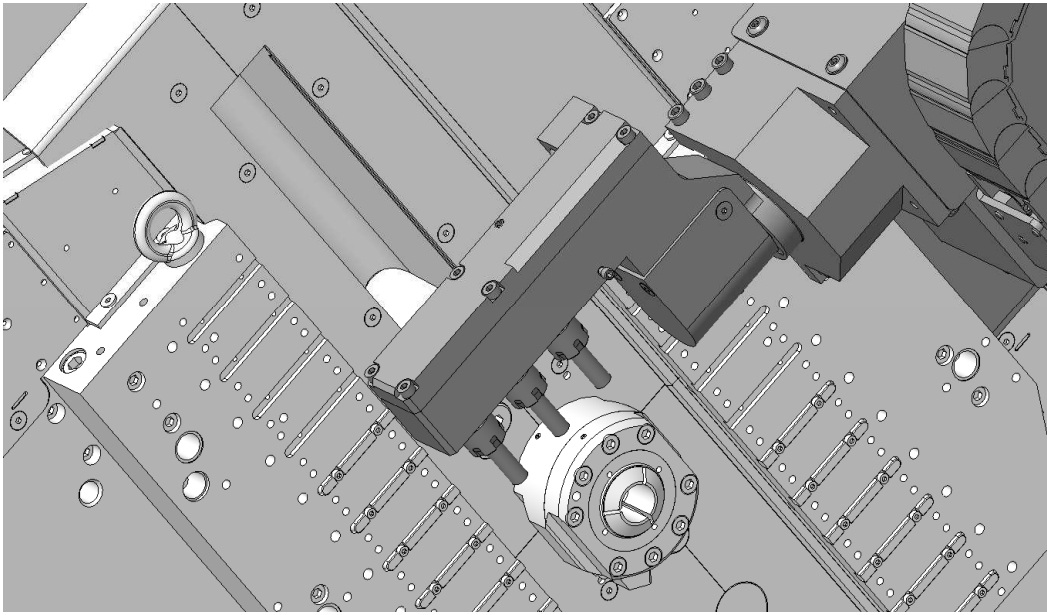

	M_{max}	n_{max}		MAX. T
R907LV2P1.01	8.8 Nm	5000 rpm	ER16	10 mm

Pneumatické vodící pouzdro

PNEUMATIC GUIDE BUSH

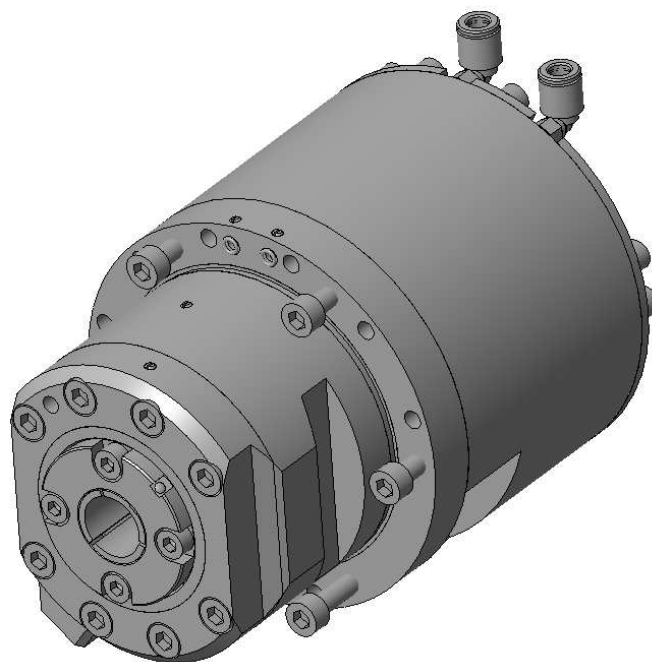

R120LD4P2

Příslušenství pro obrábění bez vodícího pouzdra

ACCESSORIES FOR MACHINING WITHOUT GUIDE BUSH

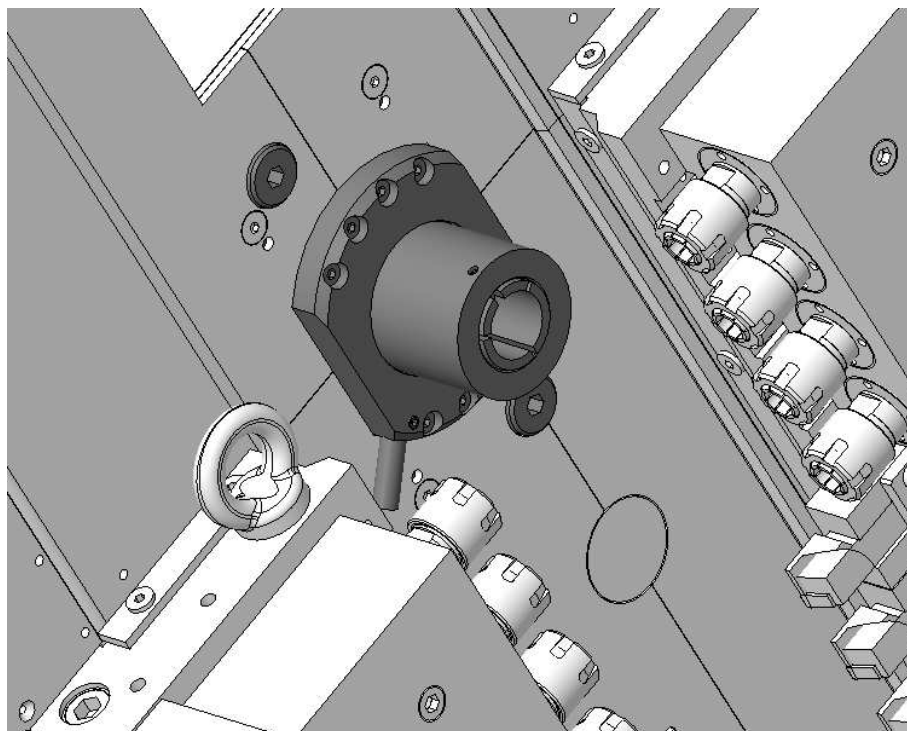

952LV39P3

Dopravník třísek listový
CHIP CONVEYOR – METALIC BELT

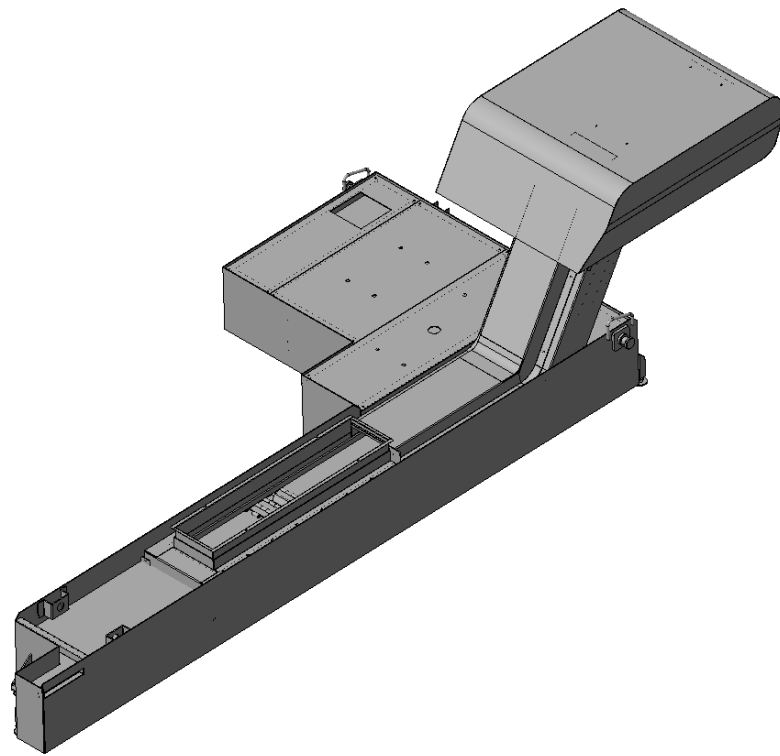

R952LV10P5.01

Vana pod stroj
TANK UNDER MACHINE

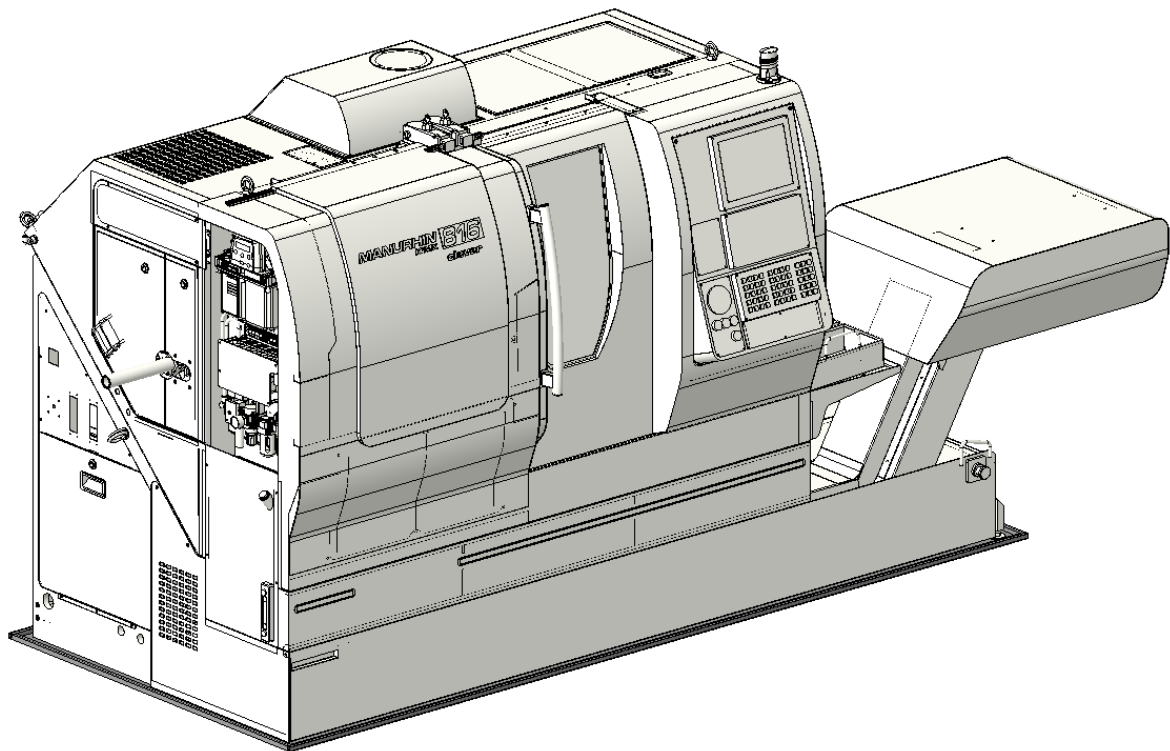

R952LV46P5

Odvod dlouhých dílců
LONG PARTS EVACUATION THROUGH THE SUBSPINDLE

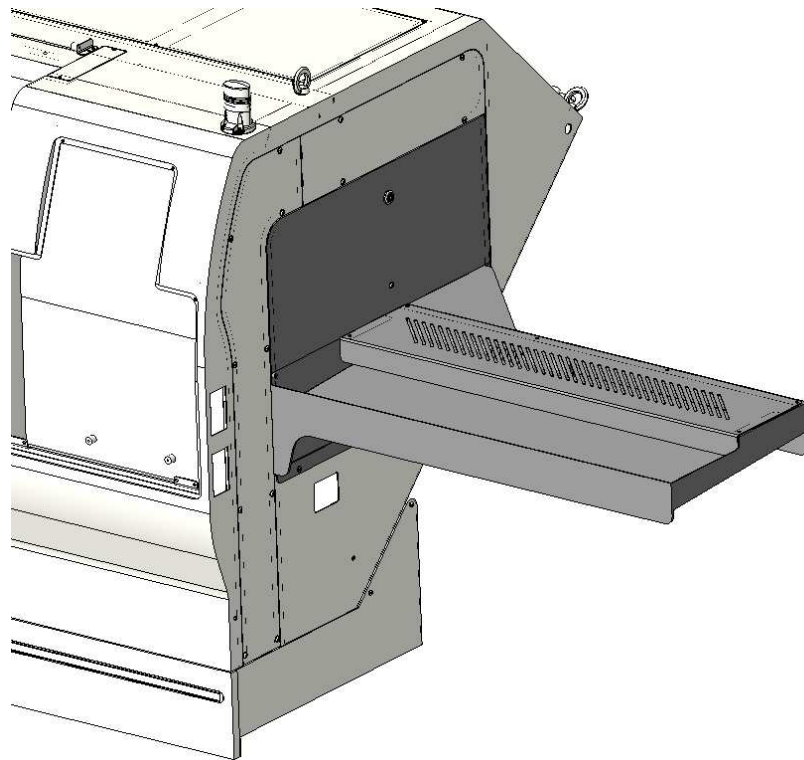

R952LV20P9

Vložka pro kleštinu

INSERT FOR COLLET

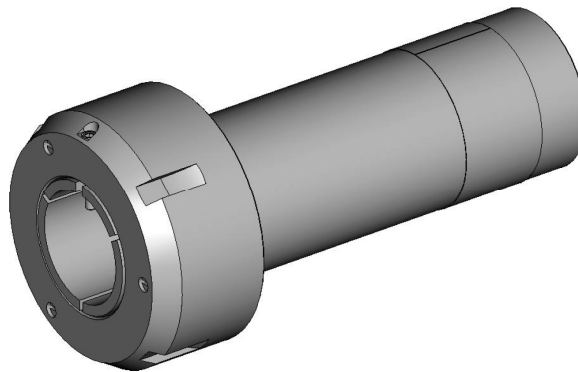
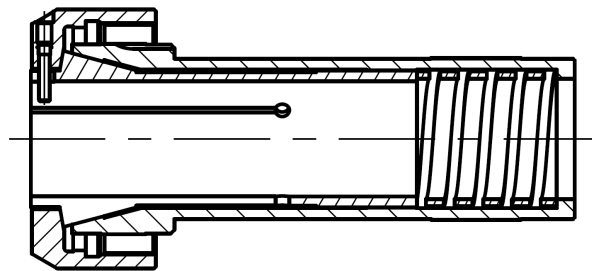

R120LD3P1 F25

R120LD3P2 F28

Příslušenství rotační jednotky

LIVE TOOL ACCESSORIES

R120LD29P1 ER16

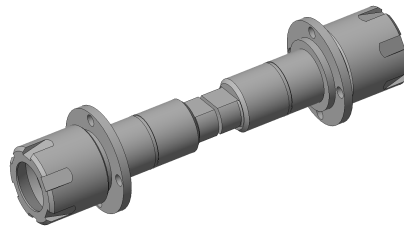

R120LD29P9 ER16

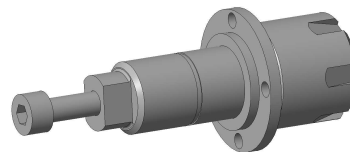

R120LD29P8 ER16

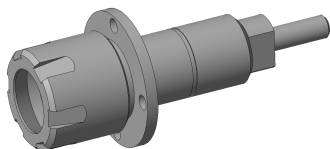

R120LD29P2

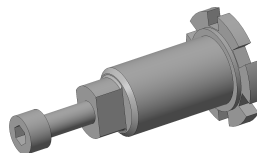

R120LD29P4

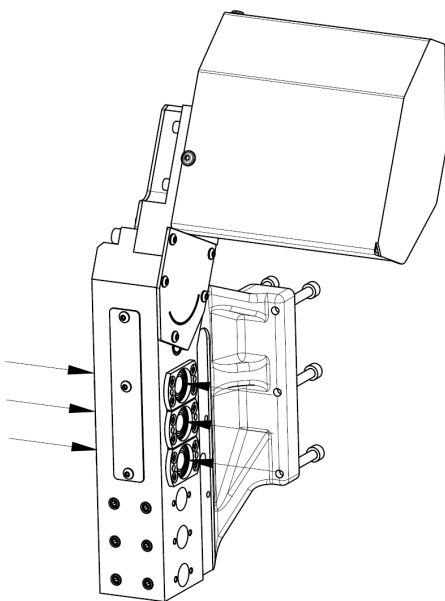
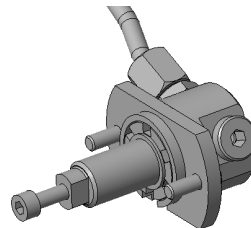

Příslušenství rotační jednotky

LIVE TOOL ACCESSORIES

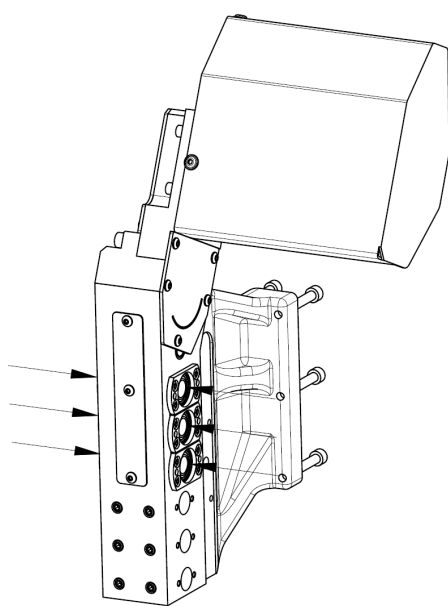

R120LD29P3 WELDON

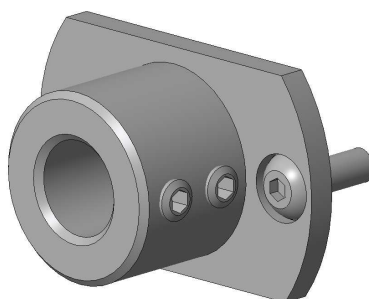

R120LD29P6 ER16

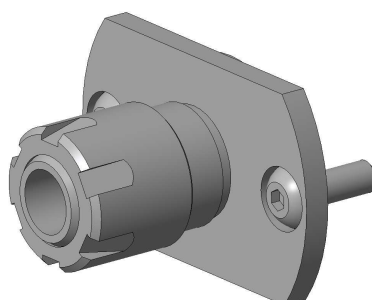

WELDON	øD
R120LD29P3	14 mm

Osový držák
AXIAL TOOLHOLDER

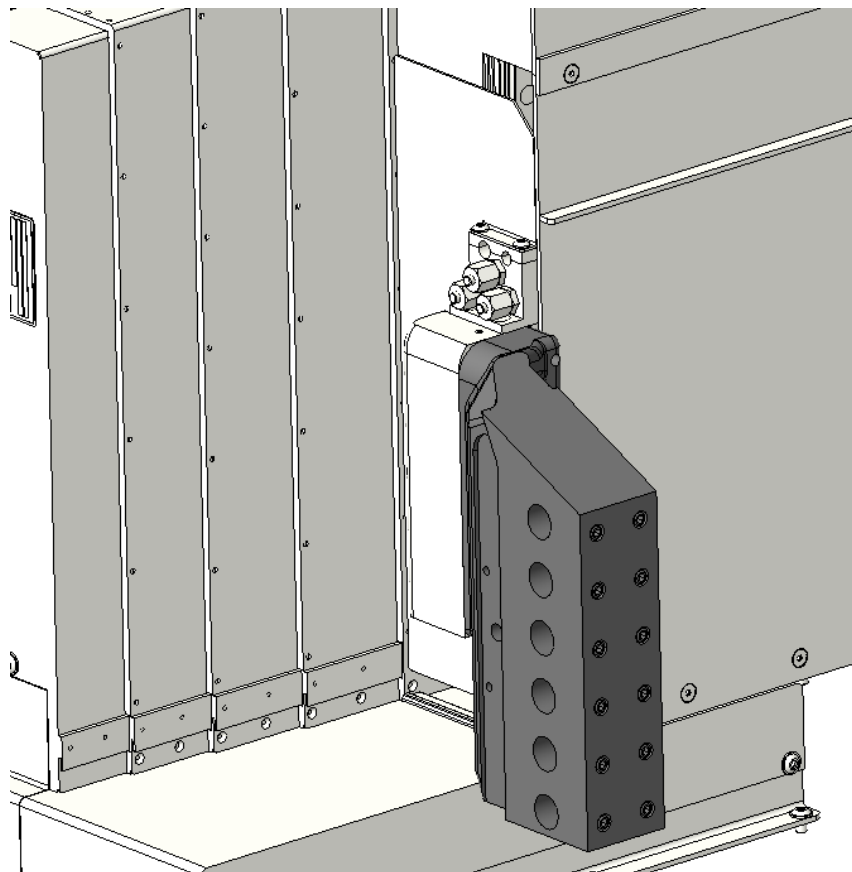

R120LR29P2

6xφ20

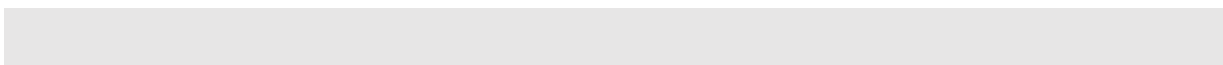
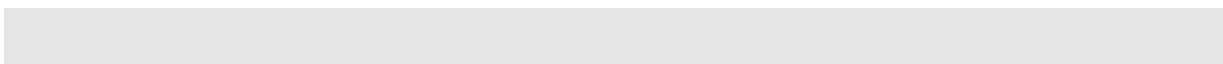
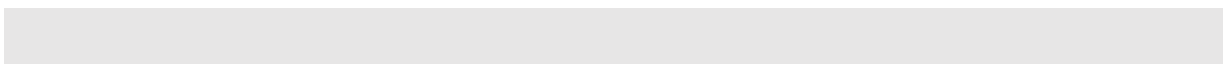

Převodovka pro jednotky WTO

GEARBOX FOR WTO UNITS

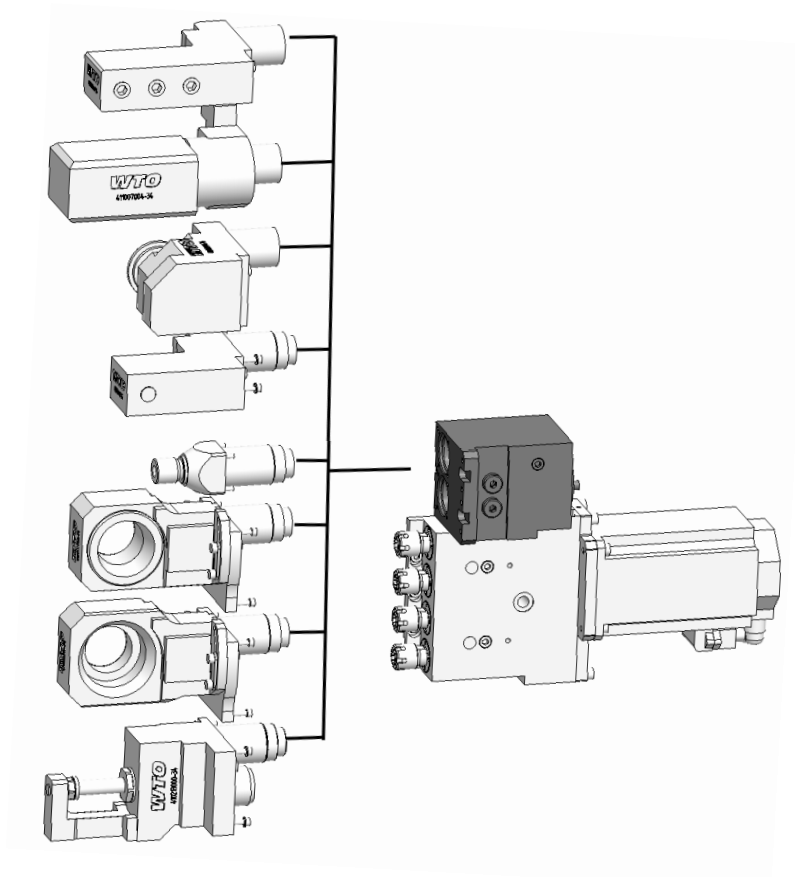

R950LV36P1

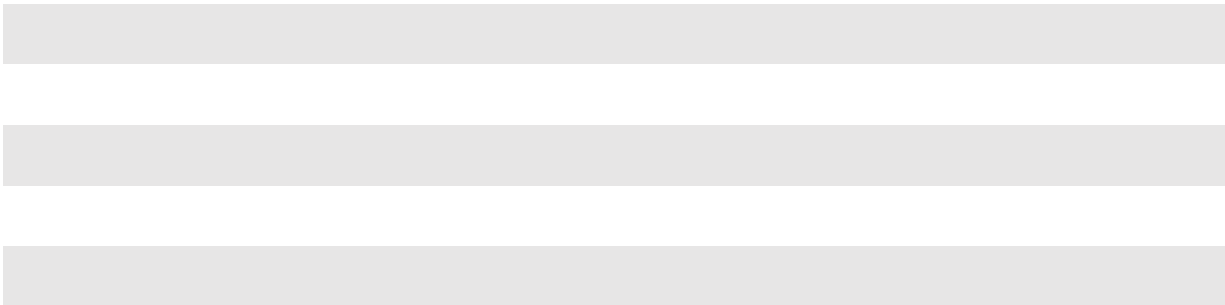

Vrtací a frézovací jednotka WTO

DRILLING AND MILLING UNIT WTO

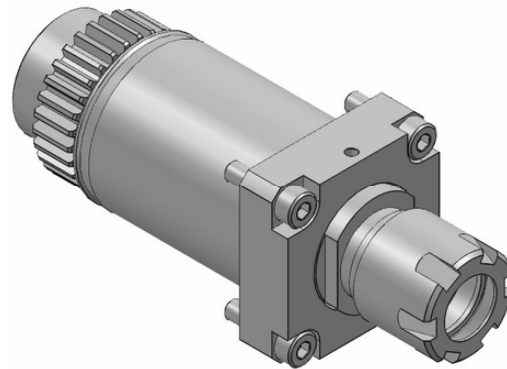
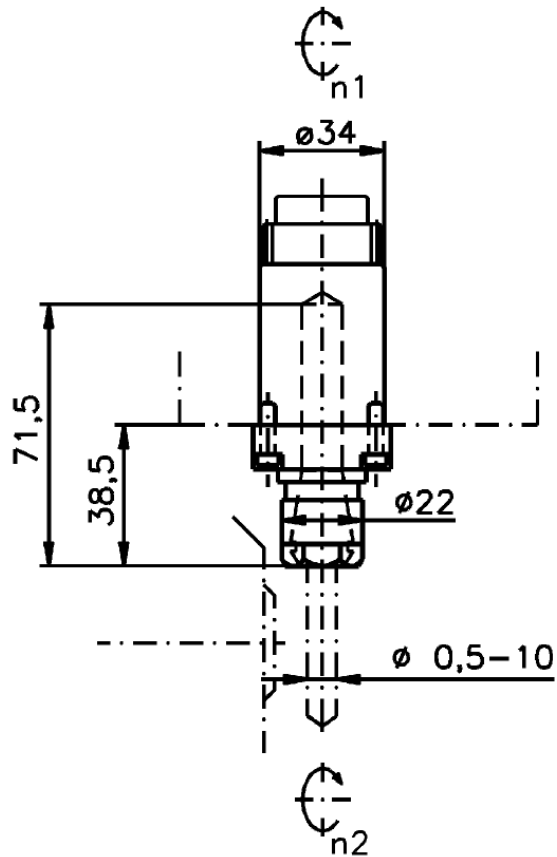

WTO number

410110000-34

ER16

Vrtací a frézovací jednotka WTO

DRILLING AND MILLING UNIT WTO

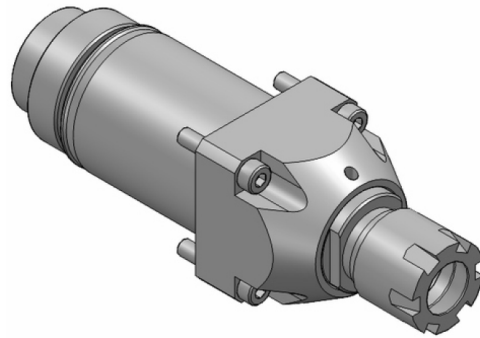
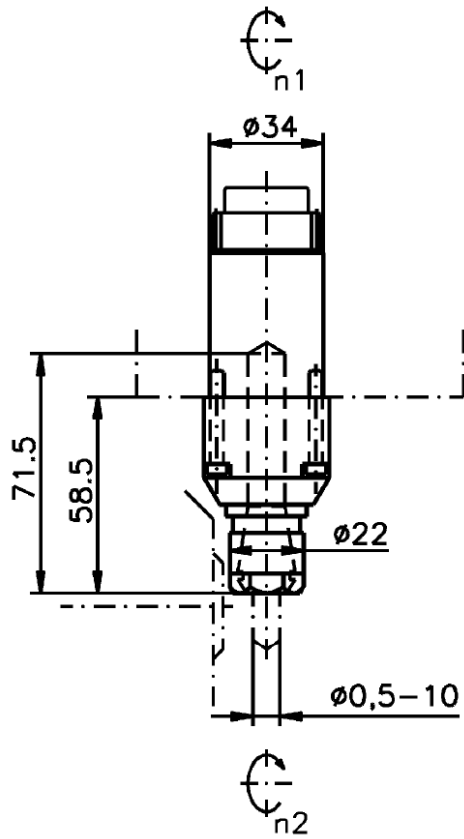

WTO number

410510003-34

ER16

Vrtací a frézovací jednotka WTO

DRILLING AND MILLING UNIT WTO

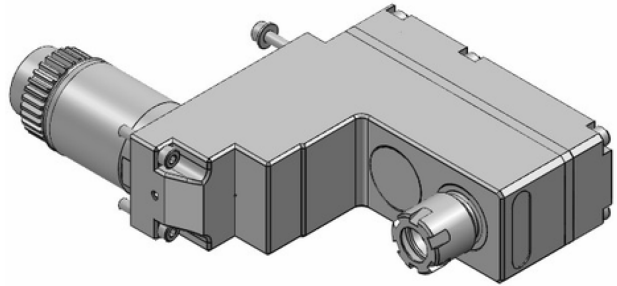
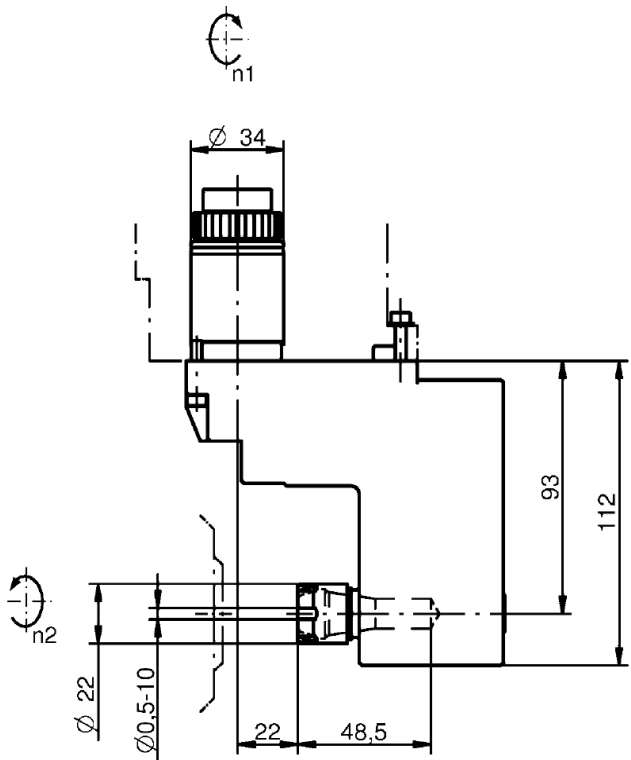

WTO number

410510003-34

ER16

Four horizontal grey bars for additional information or notes.

Vrtací a frézovací jednotka WTO

DRILLING AND MILLING UNIT WTO

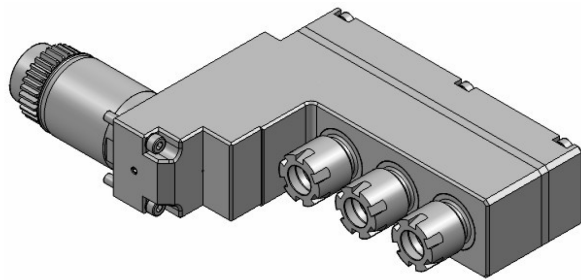
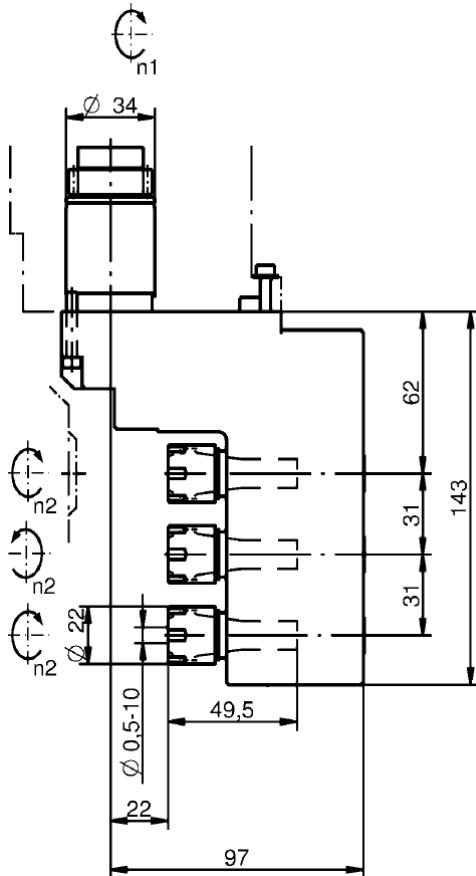

WTO number

413503000-34

ER16

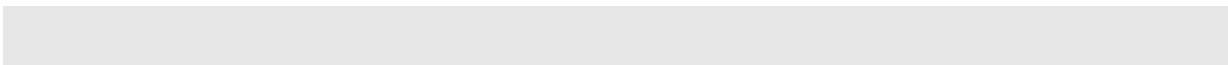
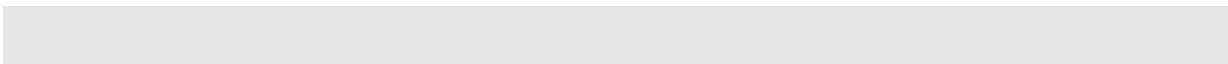
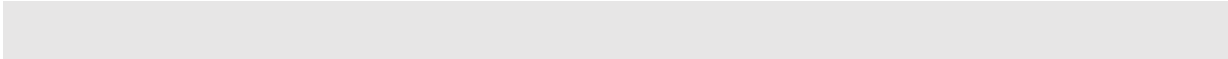

Frézovací jednotka WTO

MILLING UNIT WTO

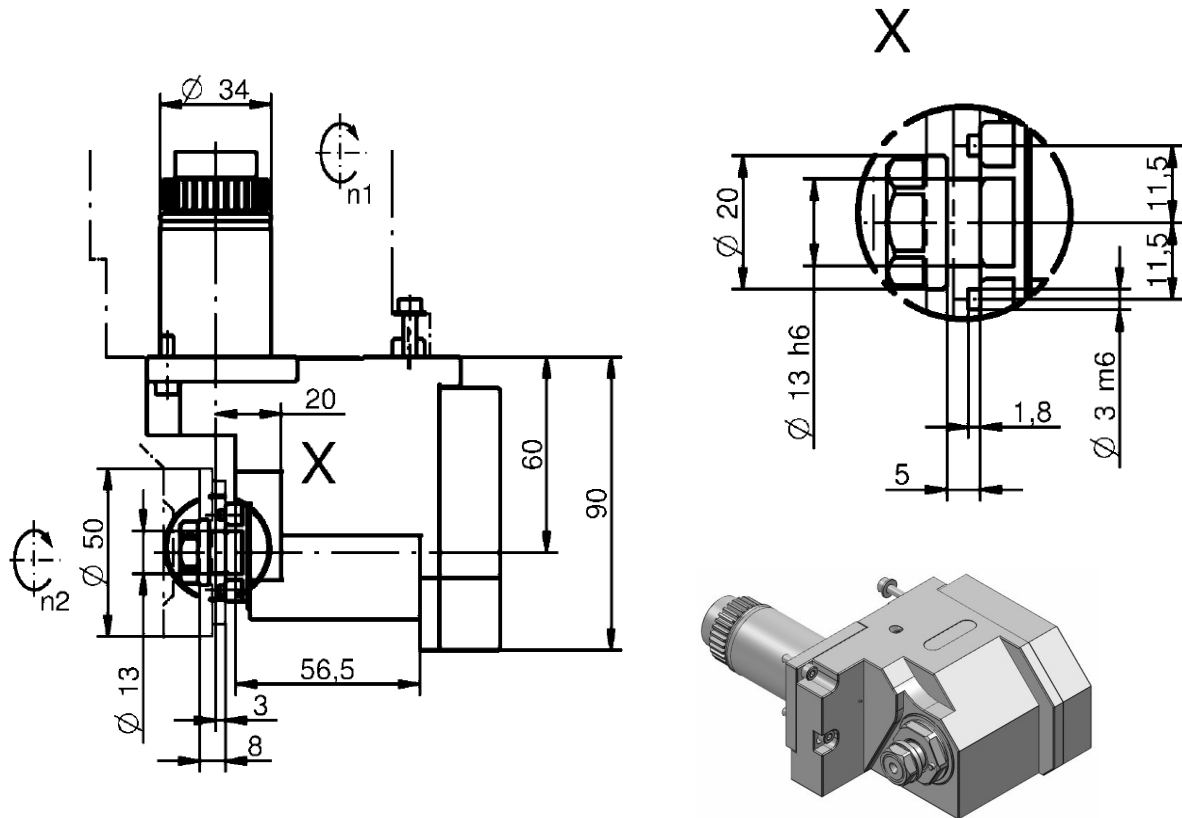

WTO number

410613000-34

Jednotka pro odvalovací frézování WTO

GEAR HOBBING UNIT WTO

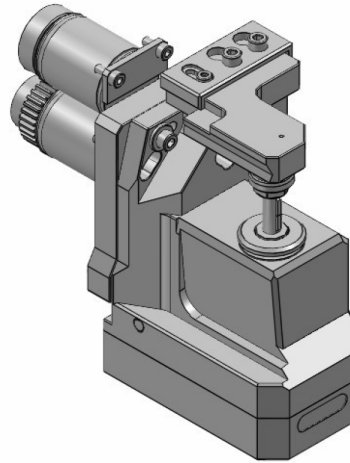
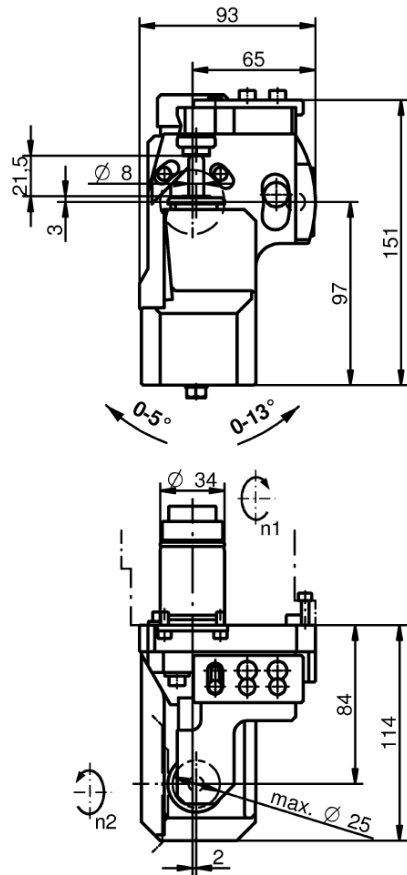

WTO number

410213000-34

Four horizontal grey bars for additional information or notes.

Úhlově nastavitelná vrtací a frézovací jednotka WTO

ADJUSTABLE ANGLE DRILLING AND MILLING UNIT WTO

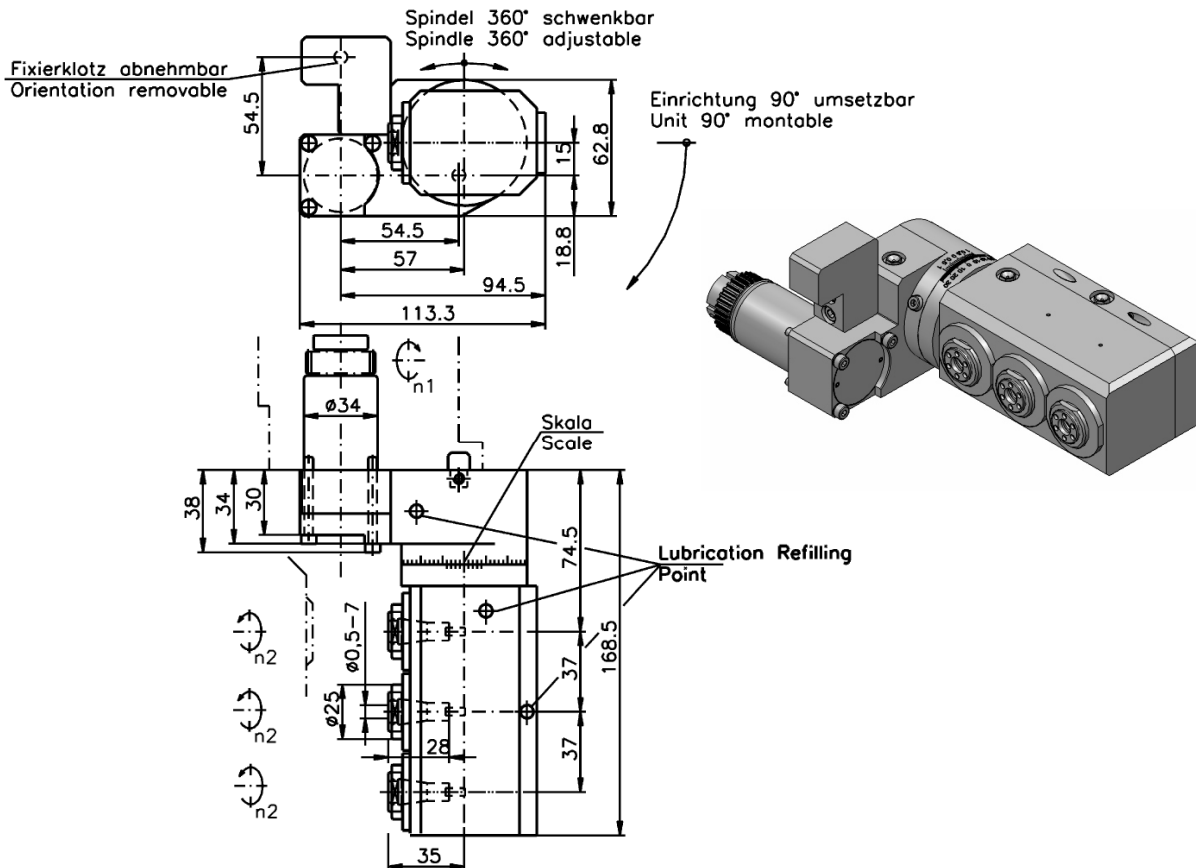

WTO number

411007004-34

Jednotka pro okružní frézování závitů WTO

THREAD WHIRLING UNIT

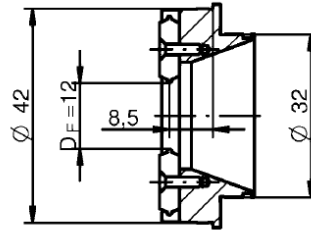
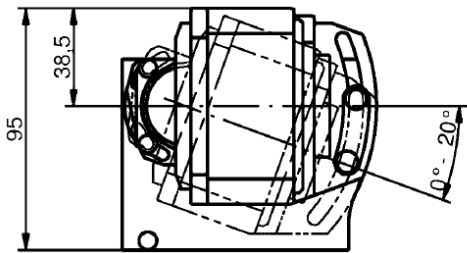

WTO Interface TN762004

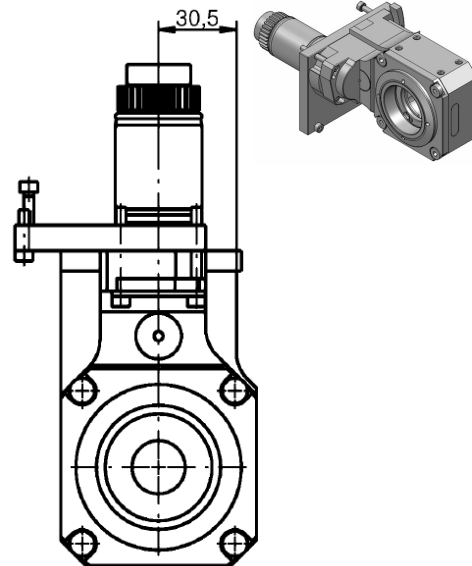
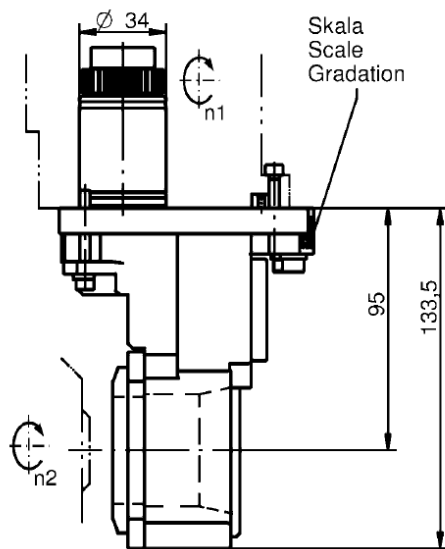

WTO number

419900002-34

Four horizontal grey bars for additional information or notes.

Jednotka pro okružní frézování závitů WTO

THREAD WHIRLING UNIT

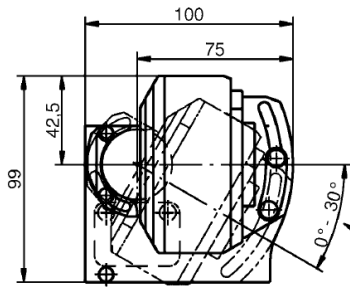

max swing angle depending on:
 - flight diameter D_F
 - bar diameter
 - thread depth

Wirbeling / Thread whirling head
 (nicht im Lieferumfang / not included)

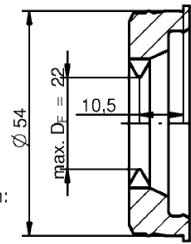

WTO Interface TN762006

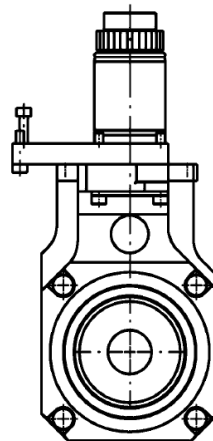
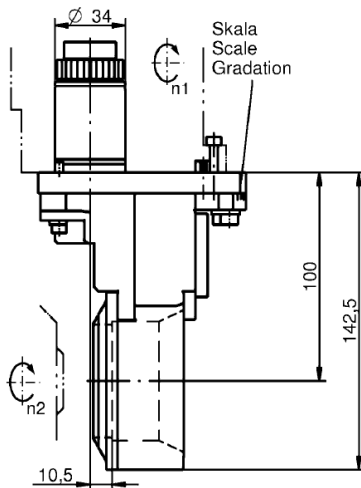
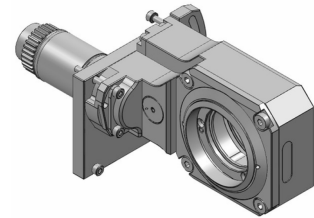

WTO number

419954003-34

Rotační jednotka pro revolverovou hlavu (KMX 916)

DRILLING AND MILLING UNIT FOR TURRET (KMX 916)

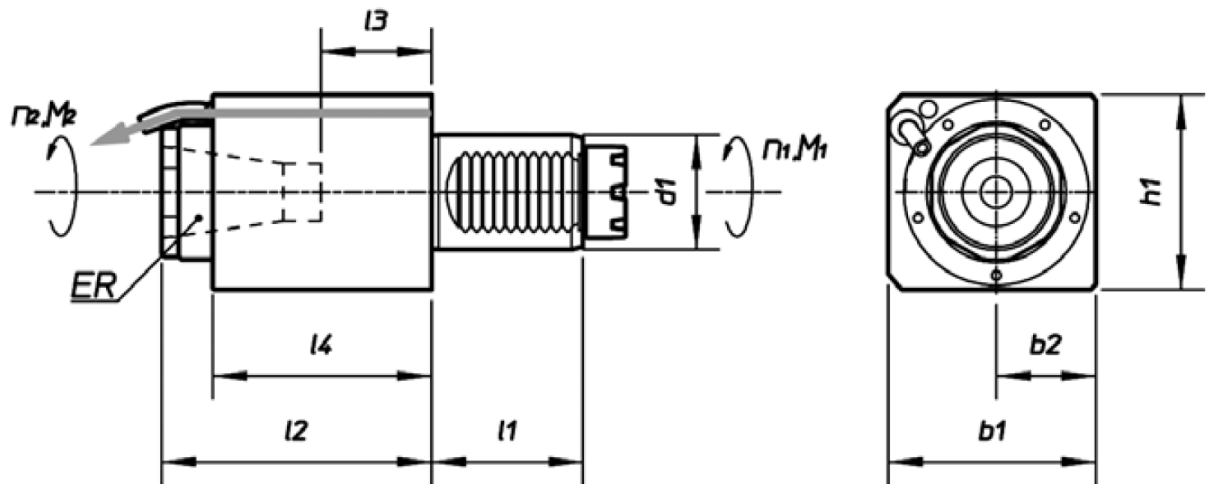

	$i=n1:n2$	$d1$	ER	$l1$	$l2$	$l3$	$l4$	$b1$	$b2$	$h1$
4151950018	1:1	20	20	35	90	49	61	50	25	56
RAPPS 20 122UB	1:4	20	16	35	100	68	85	50	25	56

Rotační jednotka pro revolverovou hlavu (KMX 916)

DRILLING AND MILLING UNIT FOR TURRET (KMX 916)

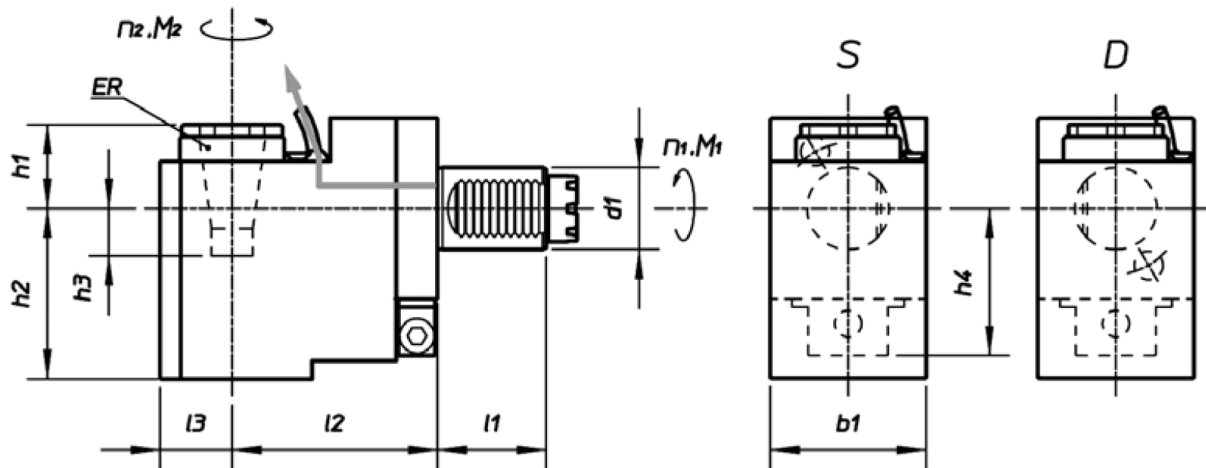

	$i=n1:n2$	$d1$	ER	$l1$	$l2$	$l3$	$b1$	$h1$	$h2$	$h3$	$h4$
RRPPA 20 321SB	1:1	20	16	35	75	26	50	28	48	4	56

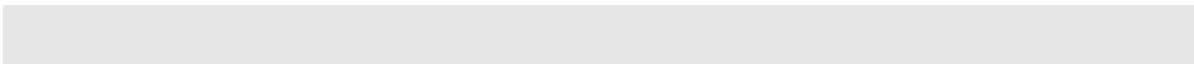
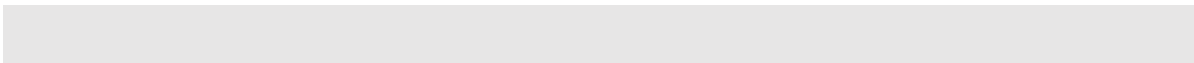
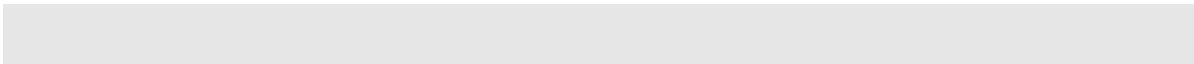

VDI držák nožů pravý (KMX 916)

VDI TOOLHOLDER RIGHT (KMX 916)

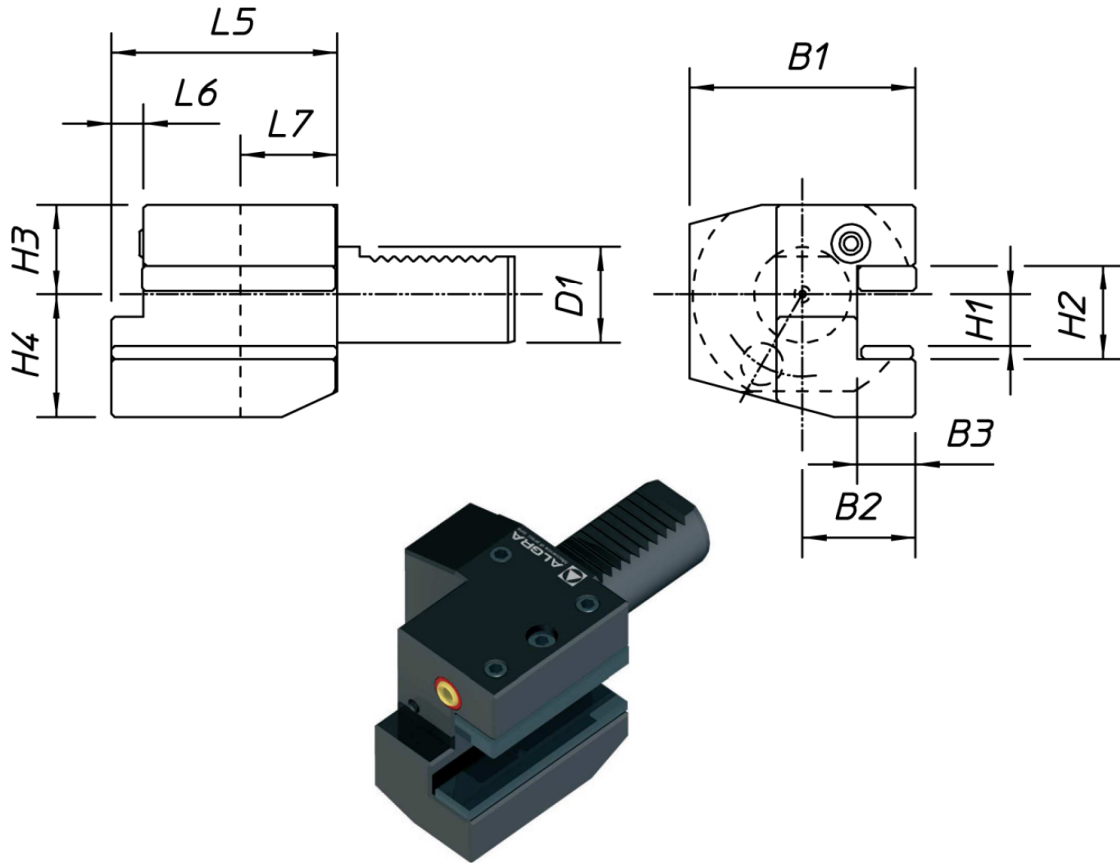

	D1	H1	H2	H3	H4	B1	B2	B3	L5	L6	L7
4151940010	20	16	22	25	30	52	27	14	55	7	30

VDI držák nožů levý (KMX 916)

VDI TOOLHOLDER LEFT (KMX 916)

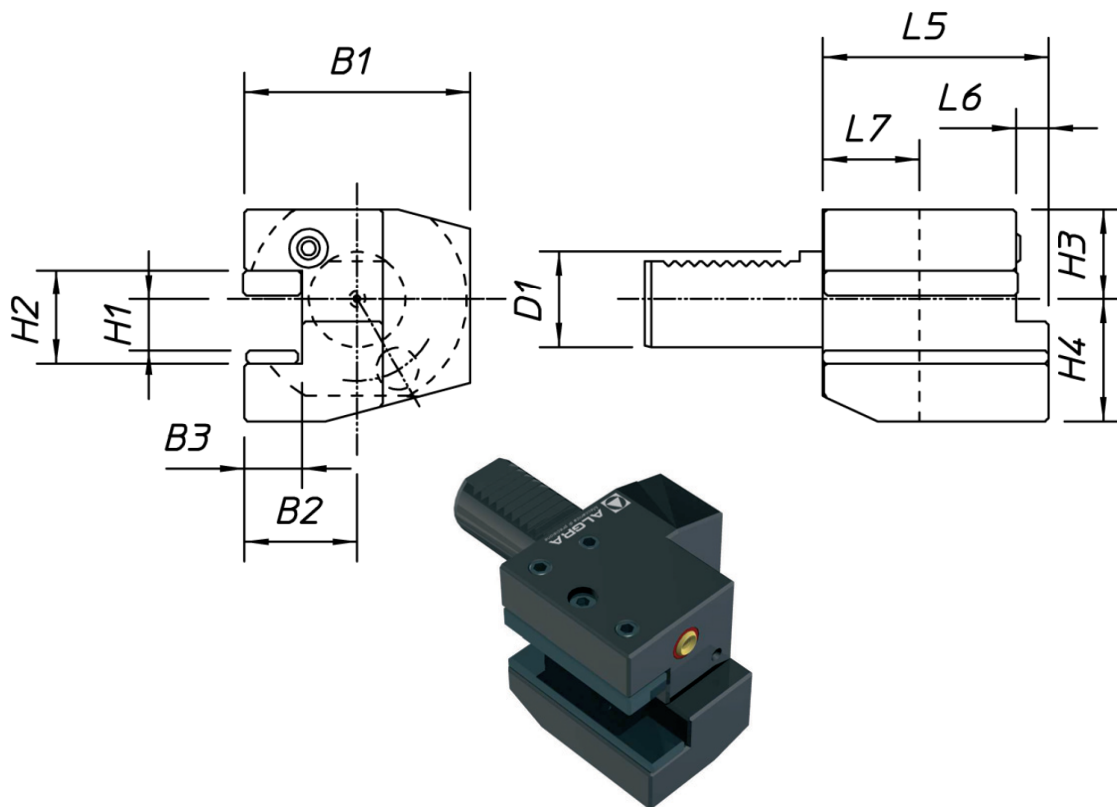

	D1	H1	H2	H3	H4	B1	B2	B3	L5	L6	L7
4151940012	20	16	22	25	30	65	40	14	50	-	30

Oplach u vodícího pouzdra

WASHING NEXT TO GUIDE BUSH

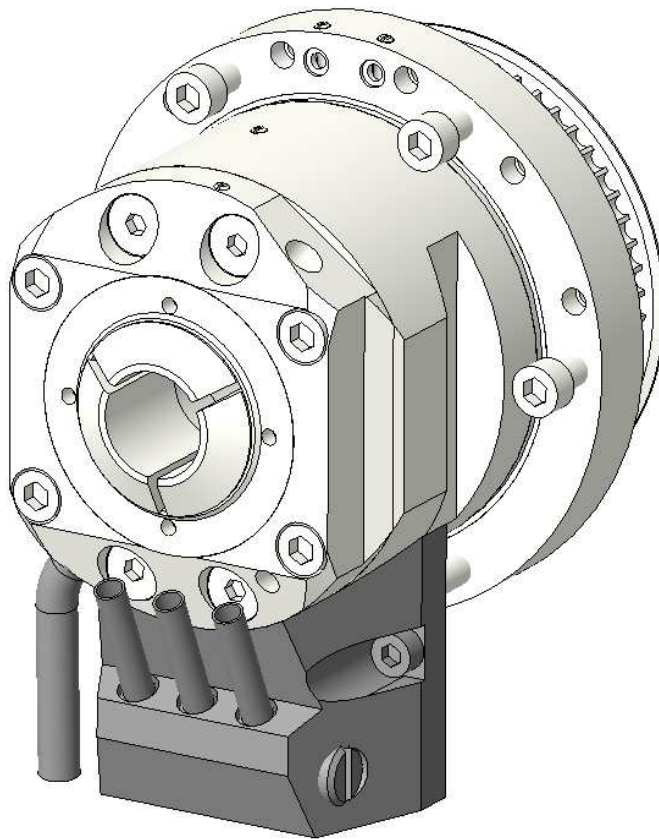

R120LR47P1.01

Držák osových nástrojů

AXIAL TOOL HOLDER

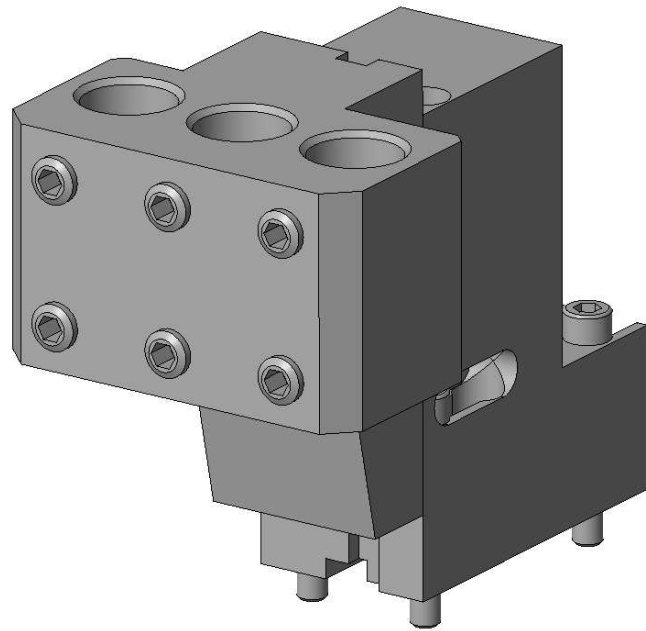
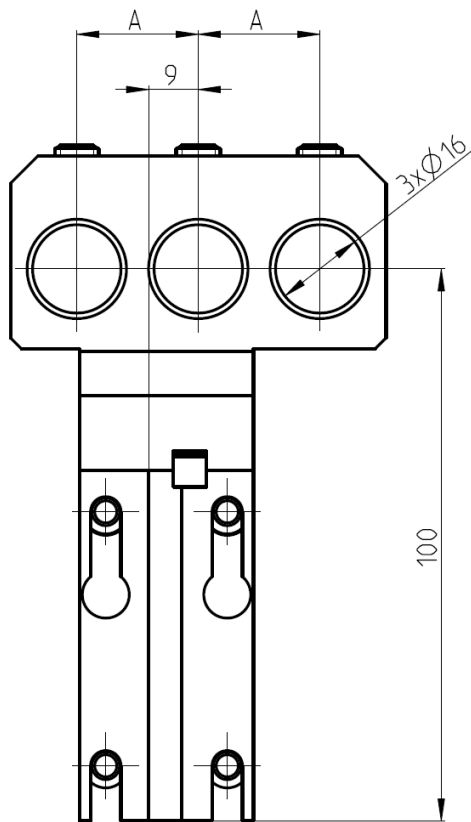

	A
R950LV3P1	22 mm
R950LV3P2	25 mm

Vysokotlaké chlazení – agregát

HIGH PRESSURE COOLING UNIT



Zdroj [<http://www.t-support.cz>]

	Flow rate	Max. pressure
952LV47P2	15 l/min	60 bar
952LV47P4	30 l/min	70 bar

Vysokotlaké chlazení – přívod chladiva
 HIGH-PRESSURE COOLING SYSTEM – SUPPLY OF COOLANT

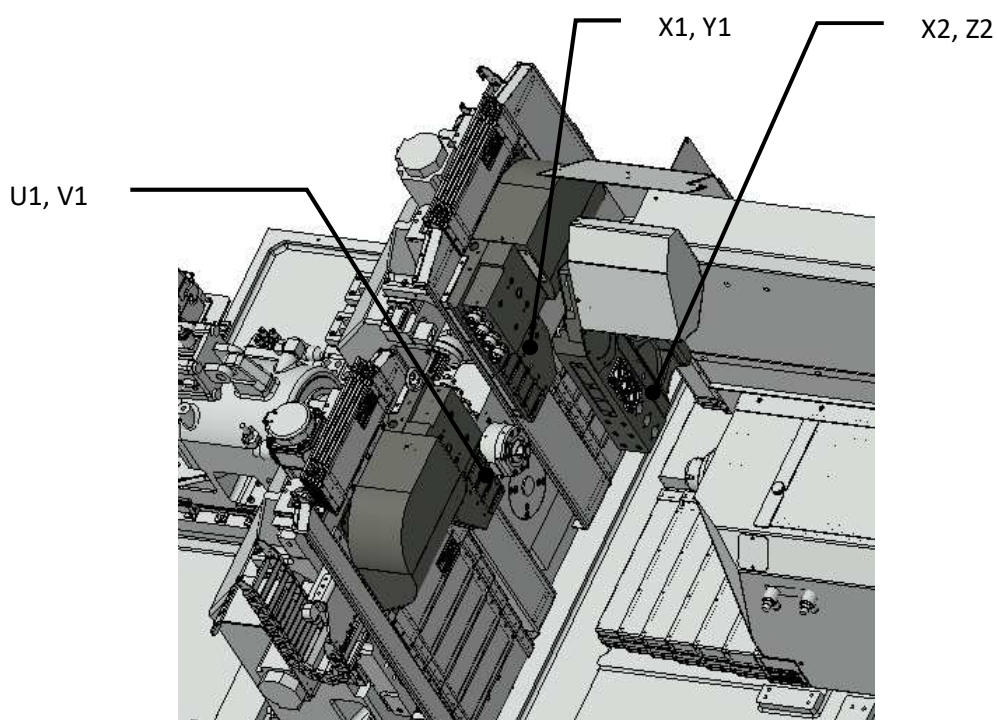

R120LR70P1 U1, V1

R120LR71P1 X1, Y1

R120LR72P1 X2, Z2

Redukce vřetene pro různé průměry materiálu

SPINDLE REDUCTIONS FOR DIFFERENT BAR DIAMETRES

SPINDELREDUKTION FÜR VERSCHIEDENE

RIDUZIONI DIAMETRO MANDRINI

TUBES DE REDUCTION DE BROCHE

ПЕРЕХОДНИКИ ШПИНДЕЛЯ ДЛЯ РАЗНЫХ ДИАМЕТРОВ ОБРАБАТЫВАЕМОГО МАТЕРИАЛА

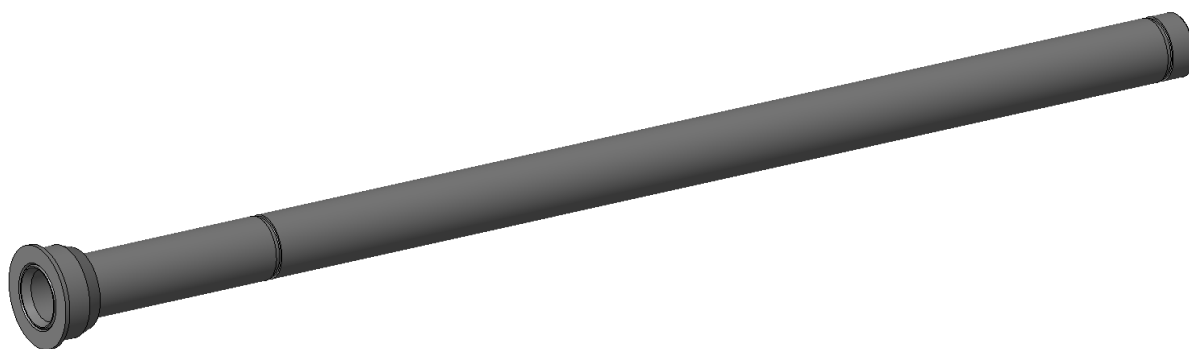
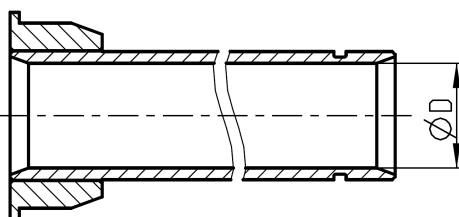

	D
952LV19P3	19 mm
952LV19P5	17 mm
952LV19P6	15 mm
952LV19P7	13 mm
952LV19P8	11 mm
952LV19P9	9 mm
952LV19P10	7 mm

Připojení podavače tyčí

BAR FEEDER CONNECTION

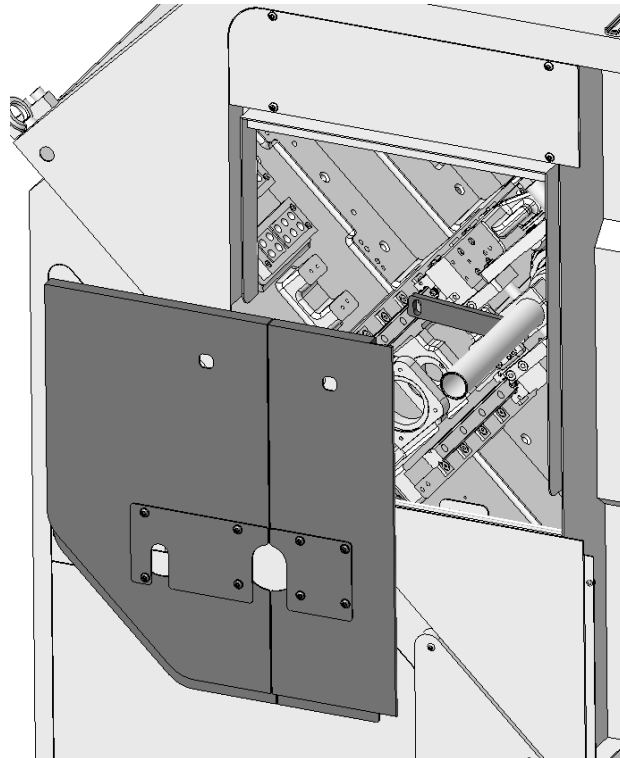

952LV1P2.01

IEMCA

Výplach protivřetena

SUBSPINDEL WASHING OUT

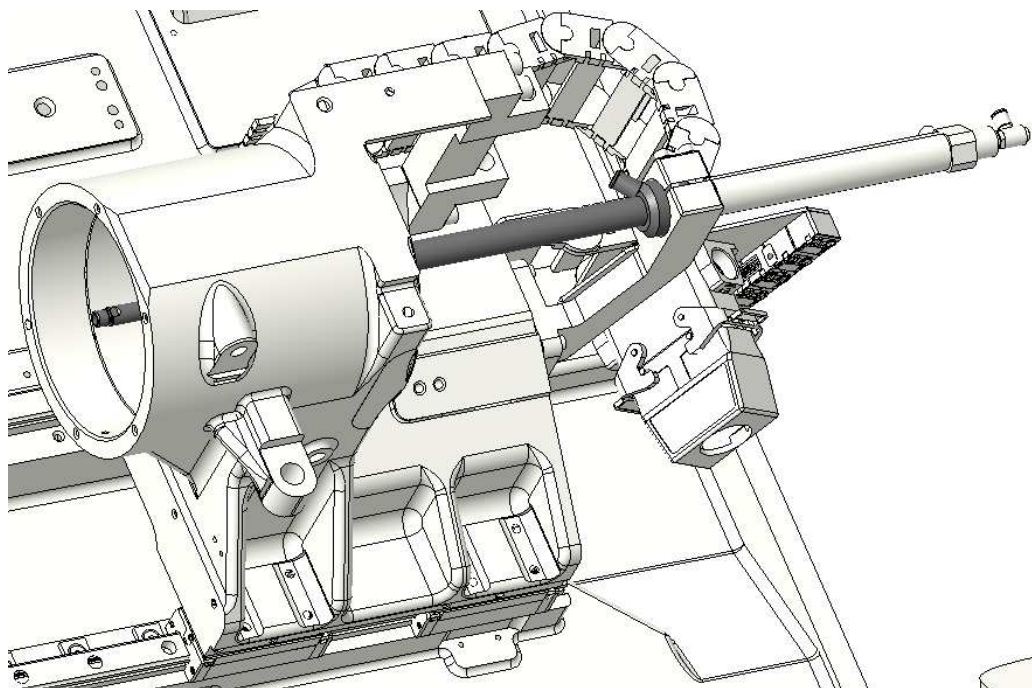

952LV54P4

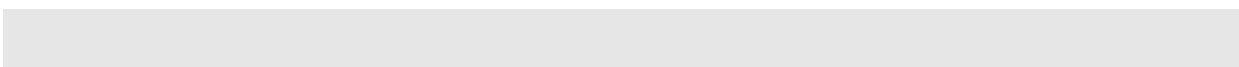
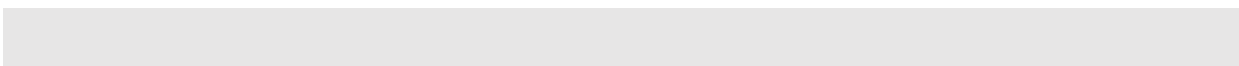

Upínání při vysokých otáčkách

SPINDLE CLAMPER FOR HIGHT SPEED

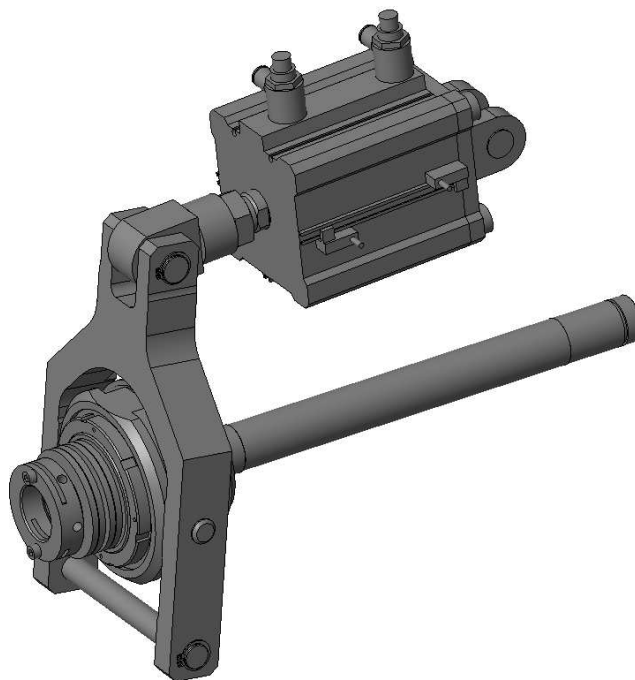

120LR11P2

Odsavač par
FUME EXTRACTOR
ASPIRATEUR DES VAPEURS



Zdroj [<http://www.filtermist.com>]

4295823010

Filtermist S400

4295823070

Filtermist S800