

## MACHINE PARAMETERS

Maximum bar diameter – main spindle	Ø 32 (*Ø 36) mm	Maximum length of part inside the counter spindle for frontal ejection	150 mm
Maximum length of turning on one stroke	400 mm	Maximum length of part for frontal ejection	170 mm
Main spindle bore	Ø 37 mm	Counter spindle bore	Ø 37 mm
Power (100% / 25%) of main spindle	15 / 25 kW	Maximum speed of counter spindle	8 000 rpm
Maximum speed of main spindle	8 000 rpm	Power (100% / 30 min) of counter spindle	3,7 / 5,5 kW
Spindle direction	Left and right	Evacuation of parts through the counter spindle (for parts max. Ø 26 mm)	Optional
Main spindle stroke	410 mm	Air pressure required	6 bar
Rapid feed of main spindle	30 m/min	Air connection by "Banjo" coupling	Ø 10 mm
Number of tool racks	2	Coolant tank capacity	300 l
Tool rack main – horizontal stroke X1, X2	45 mm	Flowrate	100 l/min
Rapid feed of horizontal stroke	30 m/min	Coolant pump pressure	5,5 bar
Tool rack main – vertical stroke Y1, Y2	193 mm	Voltage	3 x 400 V – 50 Hz
Rapid feed of vertical stroke	30 m/min	Power input	37 kVA
Tool rack axial – vertical stroke Y3	260 mm	Cable section	16 mm <sup>2</sup>
Rapid feed of axial tool rack	30 m/min	CNC control system	FANUC 31i – Model B
Tool positions (turning)	(2 x 5) + (2 x 4)	MACHINE DIMENSIONS	3 000 x 1 460 x 1 860 mm
Tools shank size OD operations counter spindle stroke	16 x 16 mm 295 mm	MACHINE WEIGHT	4 600 kg
Rapid feed of counter spindle	30 m/min		
Maximum bar diameter – counter spindle	Ø 32 (*Ø 36) mm	* optional on request	

## COLLETS AND GUIDE BUSHES



On MANURHIN K'MX 732 EVO we use for both main and counter spindle the collets of type 164E (F38) and we recommend steel ultra-precision collets from well-established collets manufacturers. Usually are used grooved collets or smooth collets or collets with longer nose (LN)



On MANURHIN K'MX 732 EVO we use the guide bushes of type T229 denomination. We recommend the guide bushes with hard metal insert from renowned manufacturers.

## MACHINE DIMENSIONS

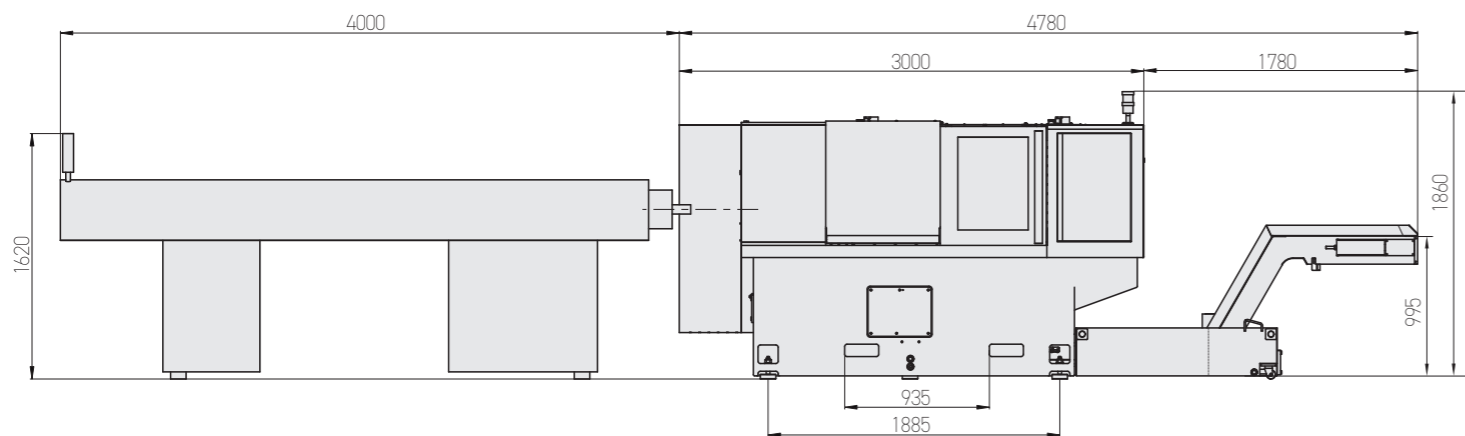

## CONTACT

**TAJMAC-ZPS, a.s.**  
třída 3. května 1180  
763 02 Zlín, Malenovice  
Czech Republic

Phone: +420 577 532 072  
Fax: +420 577 533 626  
E-mail: info@tajmac-zps.cz  
Web: www.tajmac-zps.cz

10/2021

Specifications and illustrations may not always correspond with the machine latest version.

EN

# MANURHIN K'MX 732EVO

Innovative technology



# MANURHIN K'MX 732EVO



## Innovative technology

Sliding headstock automatic lathe MANURHIN K'MX 732 EVO is designed for productive machining of parts from the bars of maximum diameter 32 mm. As the spindle bore diameter is 37 mm, there is no modification of the end of the bar for bar feeder collet needed.

Machine is equipped in standard with two electro spindles, rotary guide bush synchronized by pulleys and

belts with main spindle. Seven linear CNC axes (X1, X2, Y1, Y2, Y3, Z1, Z2) and two rotary axes (C1, C2) enable to machine with high productivity the simple as well as complex parts.

Construction solution enables of use up to 3 tools at the same time.

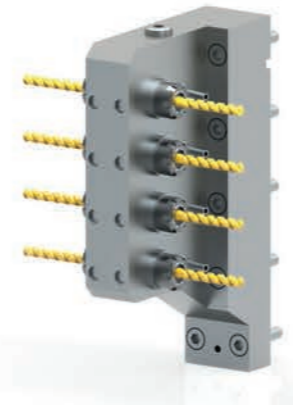

## KINEMATICS

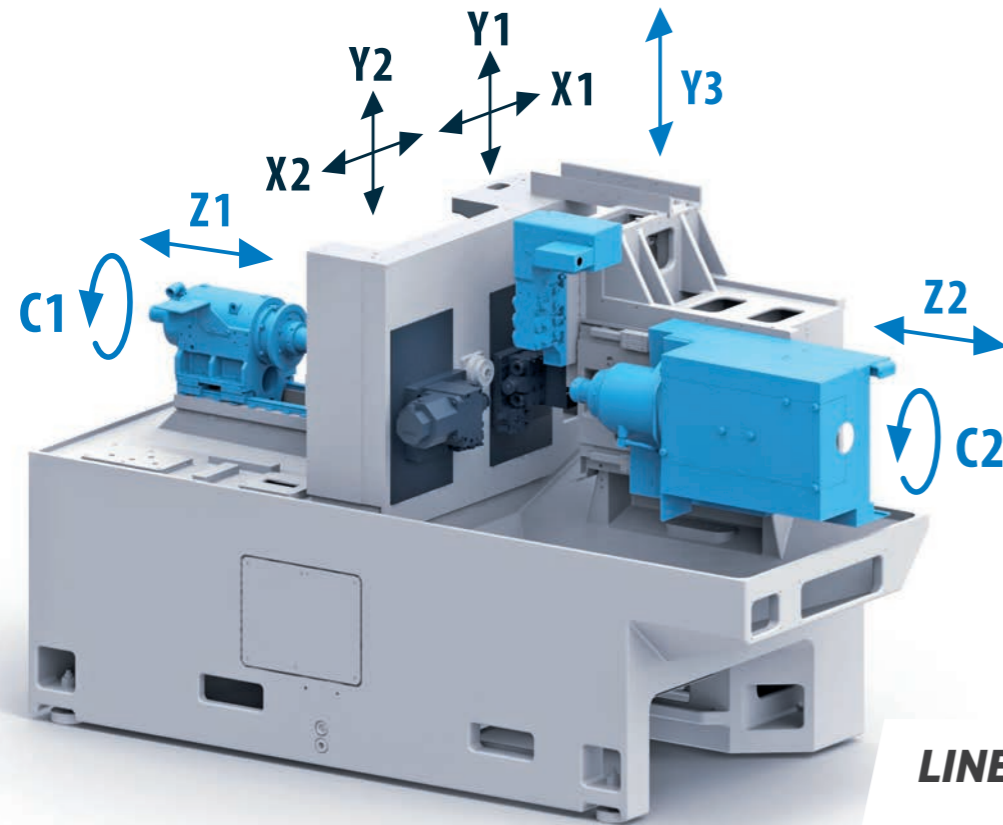

**LINEAR GUIDEWAYS**  
with rollers!

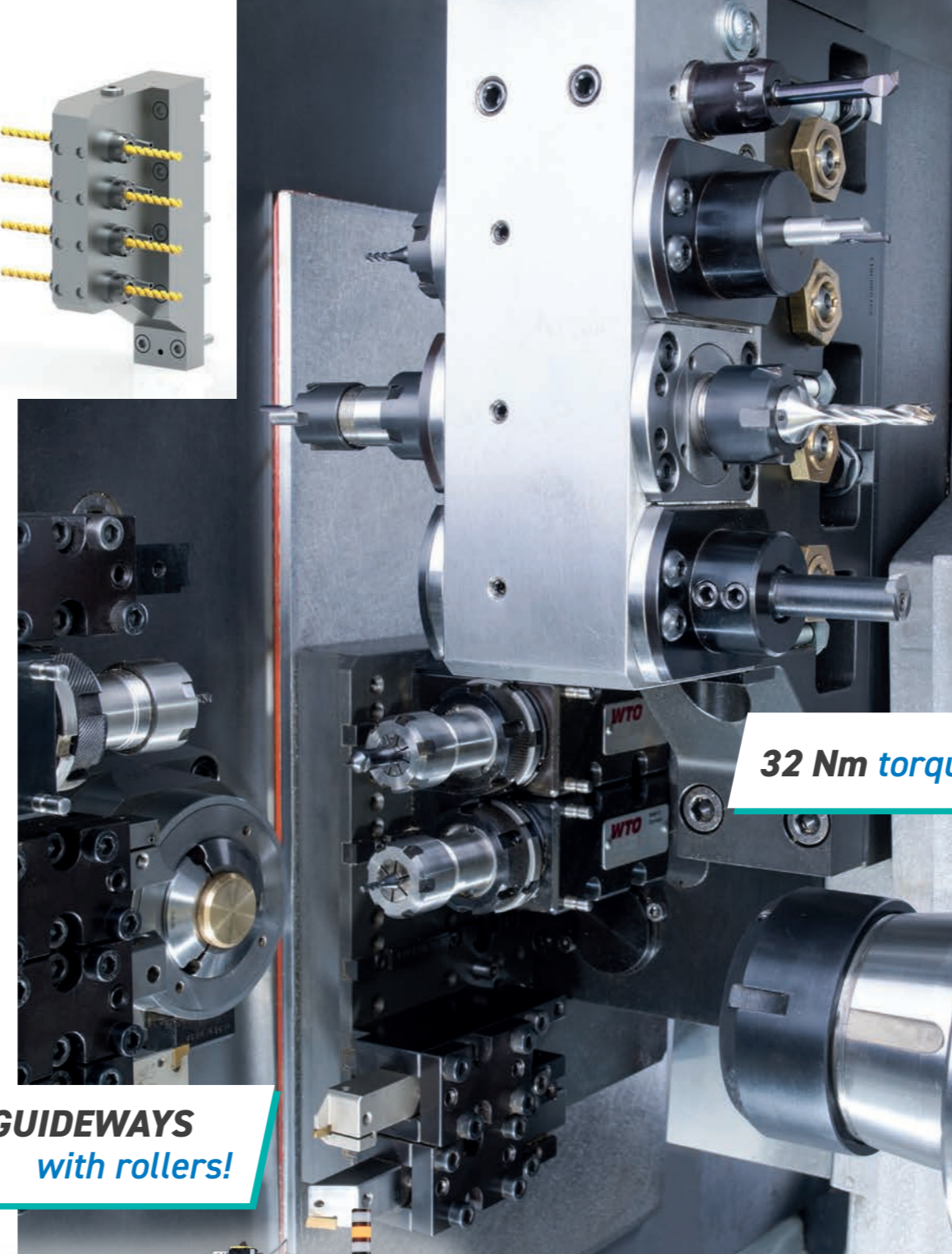

**32 Nm torque on live tools!**

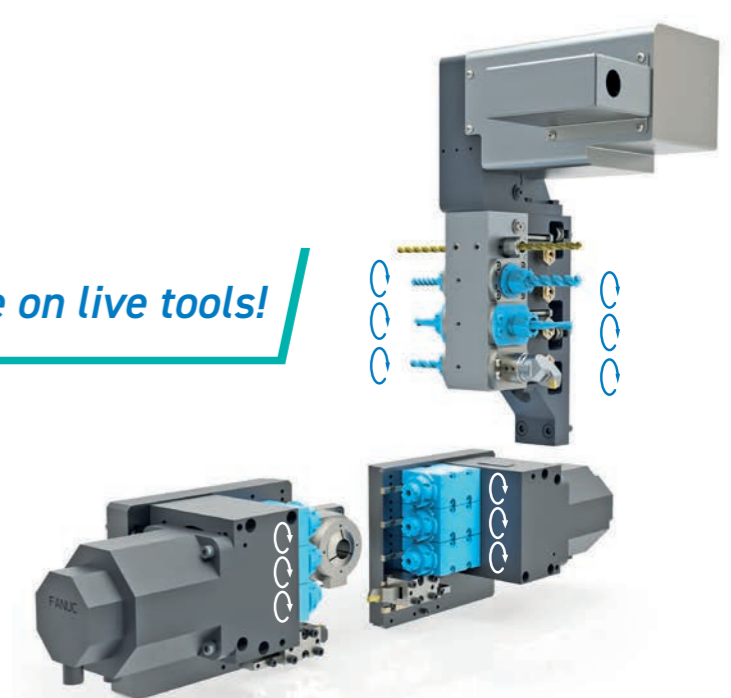

**15/25 kW spindle motor!**

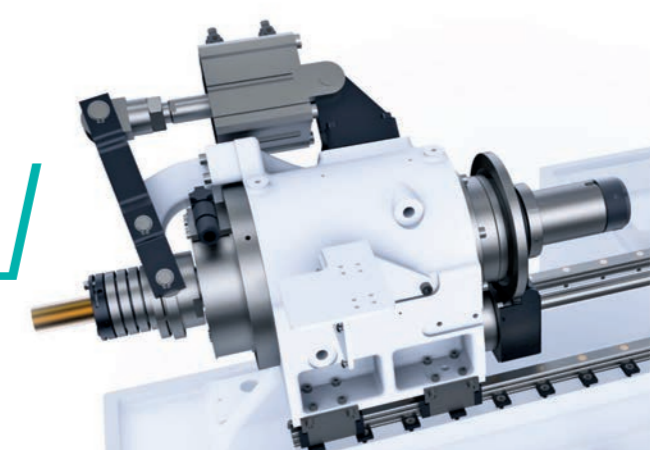

## EXTRA STRONG CLAMPING

Main headstock is fitted with electro spindle of maximum power 15/25 kW. Clamping of the main spindle is performed by strong pneumatic cylinder from SMC Company, which is providing enough clamping power for extreme turning conditions. Higher stiffness requirements of whole assembly are resolved by robust linear guides with rollers.



Big advantage of this model is possibility of parallel turning or milling with two tools at the same time. Optionally the machine can be equipped with motorized tools on both of rear or front tool rack.

The stroke of the main spindle enables to use the machine for turning of shafts up to 400 mm on one clamping. MANURHIN K'MX 732 EVO is typically delivered with automatic bar feeder with encoder and magazine for 3m bars. The parts over 170 mm long are possible to be evacuated from the machine only through the counter spindle.

The maximum length of the part is limited theoretically only by the length of the bar. The easy setup of tools on tool rack enables the successful use of this machine for the batches starting by hundreds of pieces.